



PROVENCE

ASSEMBLY INSTRUCTIONS | INSTRUCTIONS D'ASSEMBLAGE | MONTAGEANLEITUNG | ΟΔΗΓΙΕΣ
ΣΥΝΑΡΜΟΛΟΓΗΣΗΣ | MONTAGE-INSTRUCTIES | INSTRUCCIONES DE ARMADO | MONTAGE-INSTRUCTIES
| INSTRUCȚII DE ASAMBLARE | MONTAJ TALIMATLARI | ИНСТРУКЦИИ ЗА МОНТАЖ



WWW.KETER.COM

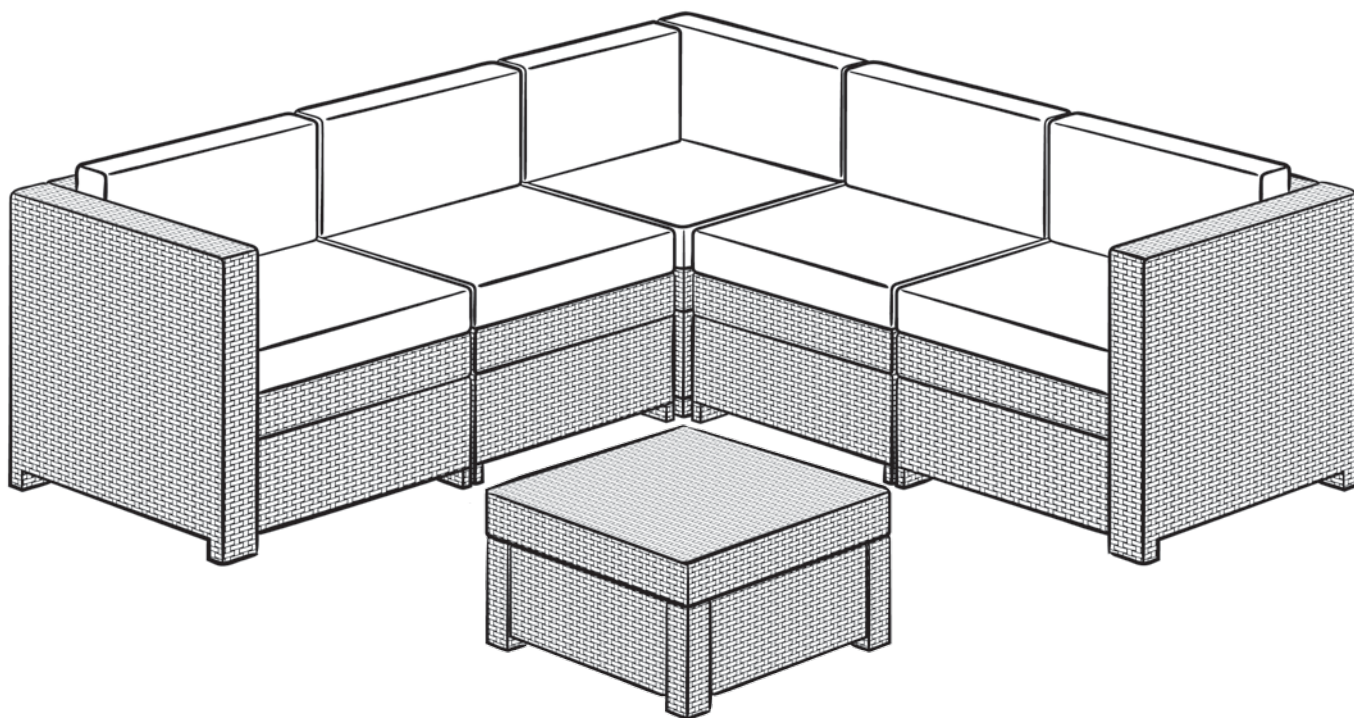

Notes and Warnings – Please Read Carefully Prior to Assembly
Notes et avertissements – Veuillez lire attentivement avant l'assemblage
Anmerkungen und Warnhinweise – Bitte sorgfältig vor der Montage lesen
Σημειώσεις και Προειδοποιήσεις – Διαβάστε προσεκτικά πριν τη συναρμολόγηση
Opmerkingen en waarschuwingen – Voor het monteren aandachtig doorlezen
Notas y advertencias: lea con atención antes de armar

- EN**
- Please assemble each piece of furniture on a flat surface.
 - A dedicated wrench is enclosed for assembly.
 - Only a standard Phillips screwdriver is required in addition to this wrench.
 - It is recommended to assemble the screws and nuts manually, and only tighten them with the enclosed wrench at the end of the assembly process.
 - It is highly recommended that you retain the wrench for future use.
 - The pieces of furniture should only be cleaned using soap, water, and a soft cloth.
 - The pieces of furniture are only intended for reasonable domestic use.
- FR**
- Veuillez assembler chaque meuble sur une surface plane.
 - Une clef spécialement prévue pour l'assemblage est incluse.
 - Seul un tournevis standard Phillips est nécessaire en plus de cette clef.
 - Il est recommandé d'assembler les vis et les écrous manuellement et de ne les serrer avec la clef fournie qu'à la fin du processus d'assemblage.
 - Il est vivement recommandé de conserver la clef pour une utilisation future.
 - Les meubles doivent être nettoyés au savon et à l'eau uniquement, et à l'aide d'un chiffon doux.
 - Les meubles sont destinés à un usage domestique raisonnable.
- DE**
- Bitte montieren Sie jedes Möbelstück auf einer glatten Fläche.
 - Ein zur Montage geeigneter Sechskantschlüssel ist beigelegt.
 - Zusätzlich zu dem Sechskantschlüssel wird noch ein normaler Kreuzschraubendreher benötigt.
 - Es wird empfohlen, alle Schrauben und Muttern per Hand einzudrehen und diese erst nach Beendigung des Zusammenbaus mit dem Sechskantschlüssel festzuziehen.
 - Bewahren Sie den Sechskantschlüssel für einen zukünftigen Gebrauch auf.
 - Zur Reinigung der Möbelstücke sind nur Seifenlauge, Wasser und ein weiches Tuch zu verwenden.
 - Die Möbelstücke sind nur zur angemessenen privaten Nutzung ausgelegt.
- EL**
- Συναρμολογήστε κάθε τεμάχιο επίπλου σε επίπεδη επιφάνεια.
 - Περιλαμβάνεται ειδικό μηχανικό κλειδί για τη συναρμολόγηση.
 - Πέραν του συγκεκριμένου μηχανικού κλειδιού, απαιτείται ένα απλό κατσαβίδι Phillips.
 - Προτείνεται να συναρμολογήσετε τις βίδες και τα παξιμάδια με το χέρι, και να τα σφίξετε με το μηχανικό κλειδί που περιλαμβάνεται, στο τέλος της διαδικασίας συναρμολόγησης.
 - Σας συμβουλεύουμε να φυλάξετε το μηχανικό κλειδί για μελλοντική χρήση.
 - Τα τεμάχια επίπλων πρέπει να καθαρίζονται χρησιμοποιώντας μόνο σαπούνι και νερό, με τη βοήθεια μαλακού υφάσματος.
 - Τα τεμάχια επίπλων προορίζονται μόνο για εύλογη οικιακή χρήση.
- NL**
- Monteer elke meubelstuk op een vlakke ondergrond.
 - Voor de montage is een passende sleutel bijgesloten.
 - Behalve deze sleutel hebt u ook een standaard kruisschroevendraaier nodig.
 - Het wordt aangeraden om de schroeven en moeren handmatig vast te draaien en ze alleen aan het einde van de montageprocedure met de bijgesloten sleutel vast te zetten.
 - Het wordt aangeraden dat u de sleutel voor toekomstig gebruik bewaard.
 - De meubels mogen alleen met zeep, water en een zachte doek worden gereinigd.
 - De meubels zijn alleen bestemd voor redelijk huishoudelijk gebruik.
- ES**
- Arme el mueble sobre una superficie plana.
 - Se incluye una llave especial para el armado.
 - Sólo se requiere un destornillador Phillips estándar, además de esta llave.
 - Se recomienda colocar los tornillos y tuercas manualmente y ajustarlos sólo con la llave incluida, al finalizar el proceso de armado.
 - Se le aconseja especialmente que conserve la llave para uso futuro.
 - Los muebles sólo deben limpiarse utilizando jabón, agua, y un trapo suave
 - Los muebles están diseñados para un uso doméstico razonable.

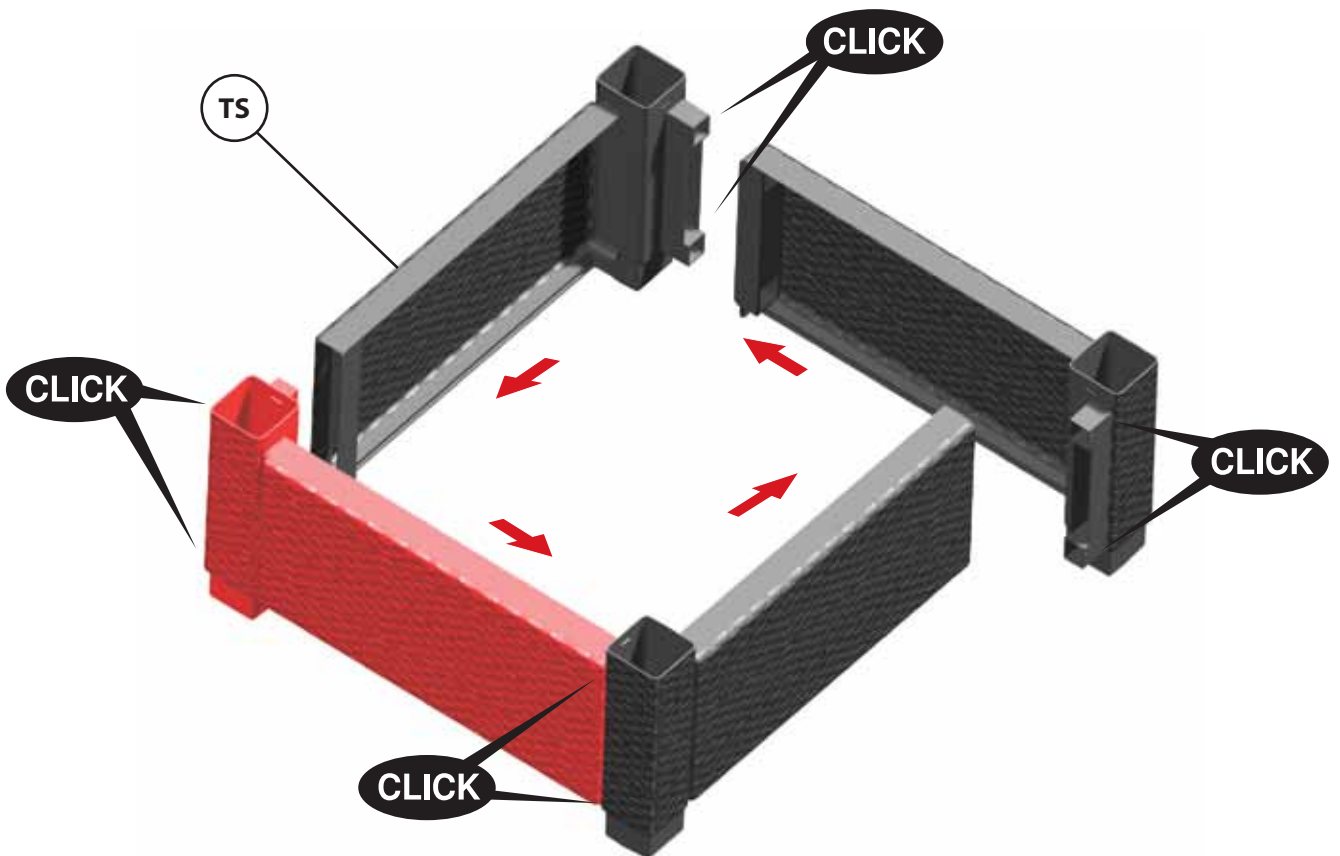
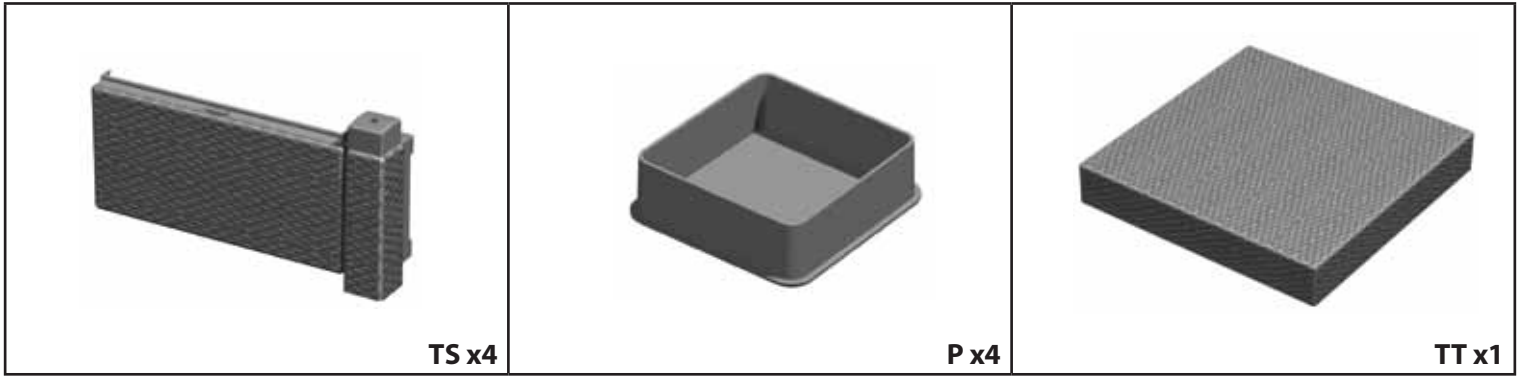
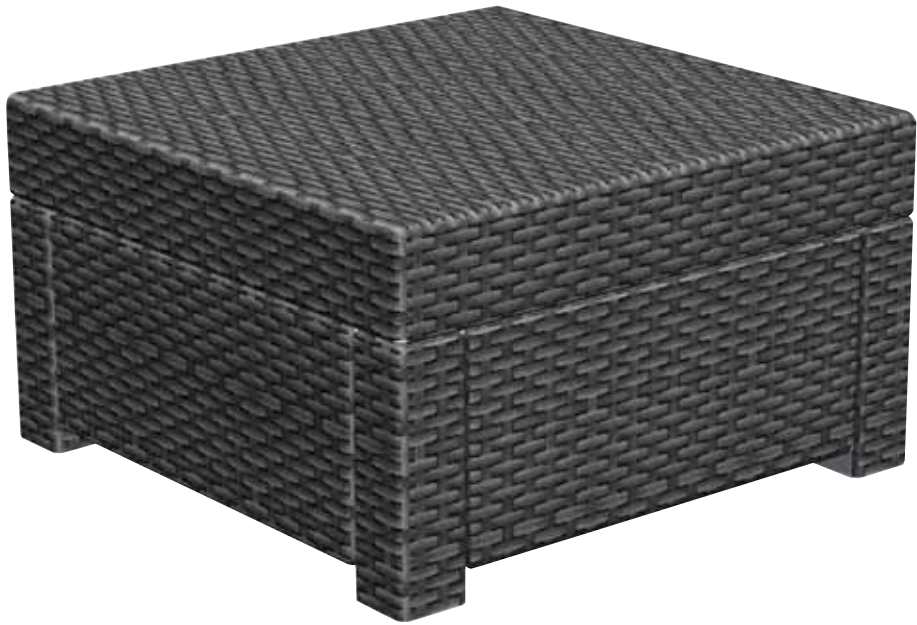

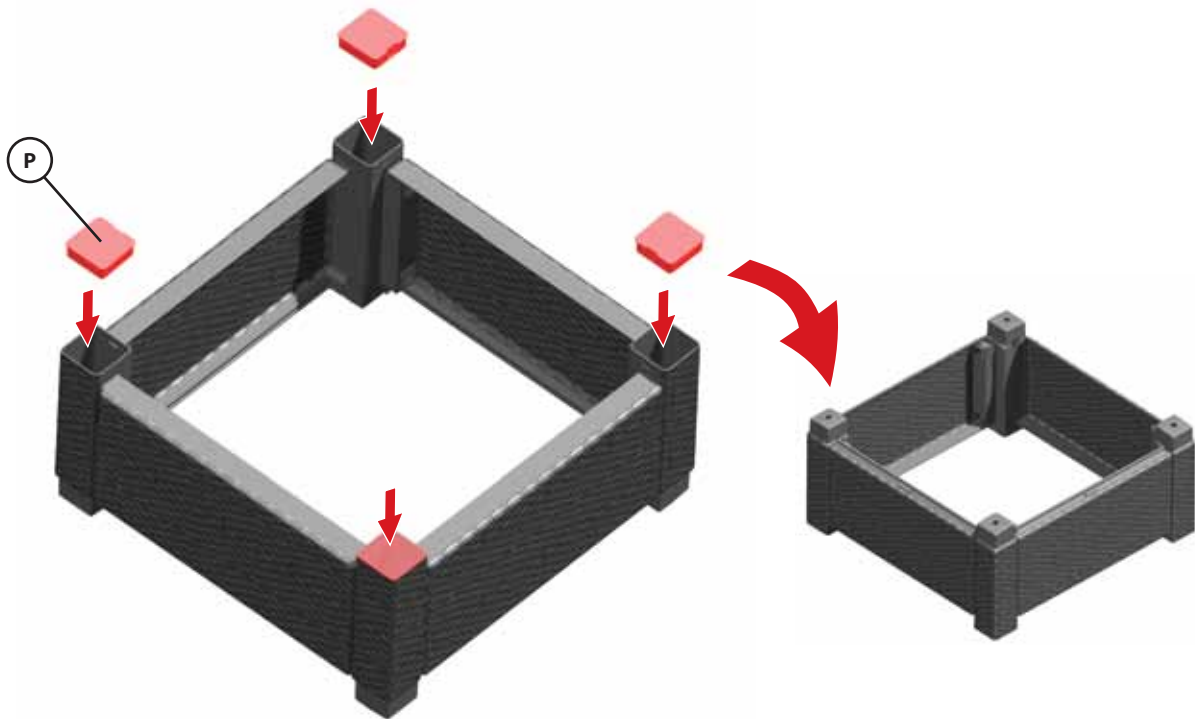

2

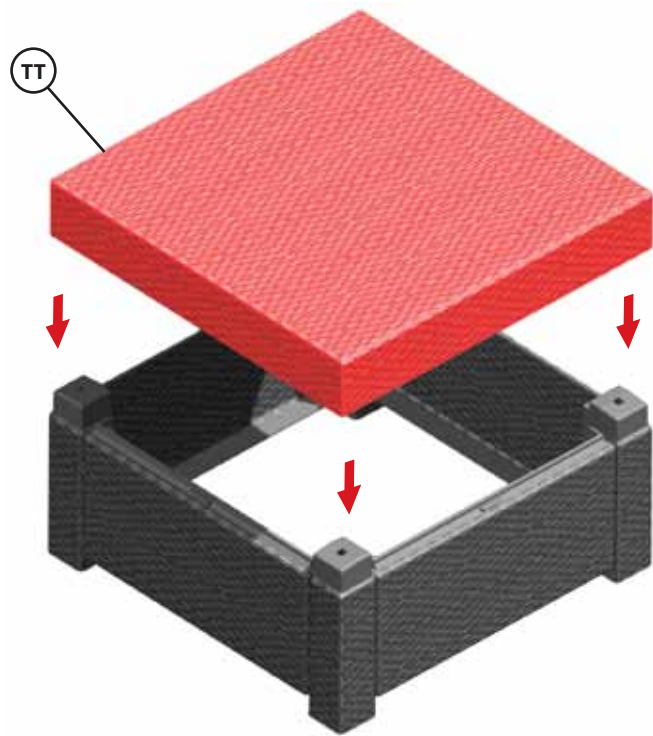

3

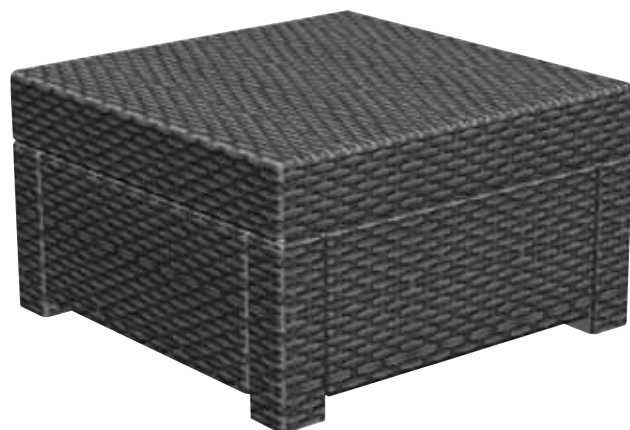

4



<p>F x1</p>	<p>LS x1</p>	<p>SP x2</p>	<p>G x1</p>
<p>PR x1</p>	<p>BC x1</p>	<p>x4</p>	<p>x1</p>
<p>S x2</p>	<p>L x1</p>	<p>x1</p>	<p>x20</p>
<p>x1</p>	<p>x1</p>	<p>x18</p>	<p>x1</p>
<p>x1</p>	<p>x1</p>	<p>x1</p>	<p>x2</p>

F

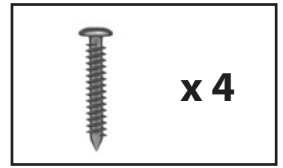
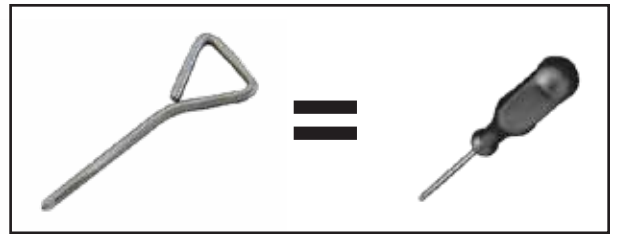
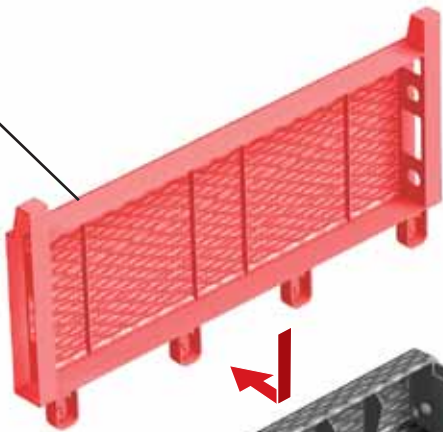

S



1

L

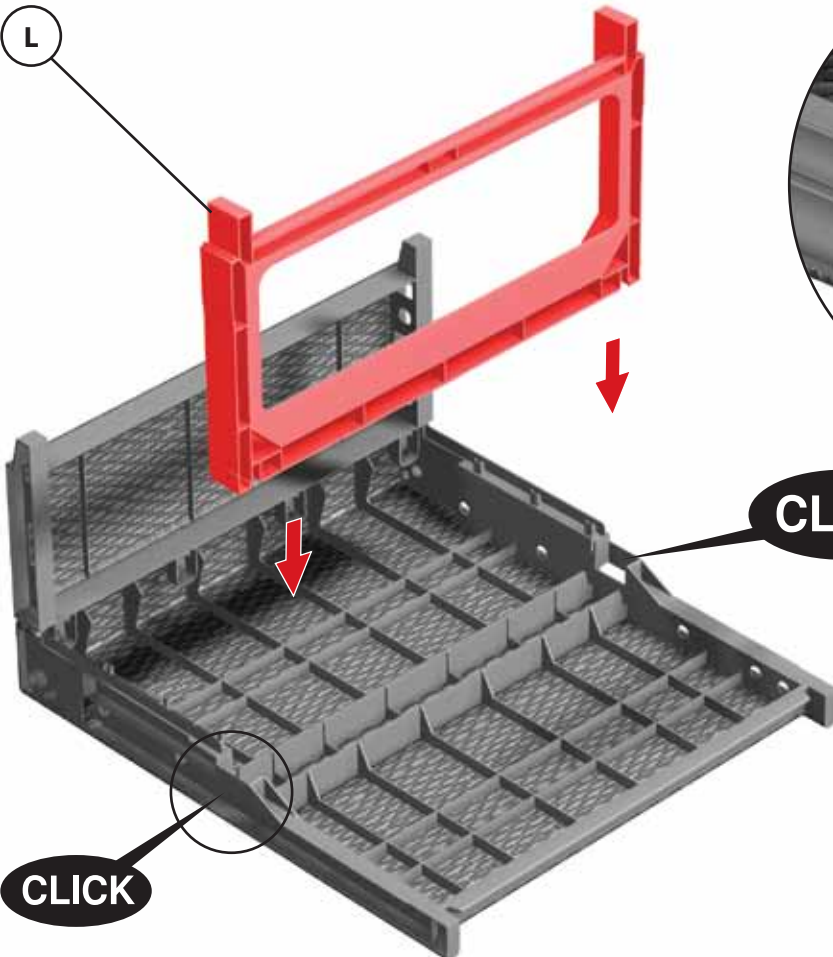

2

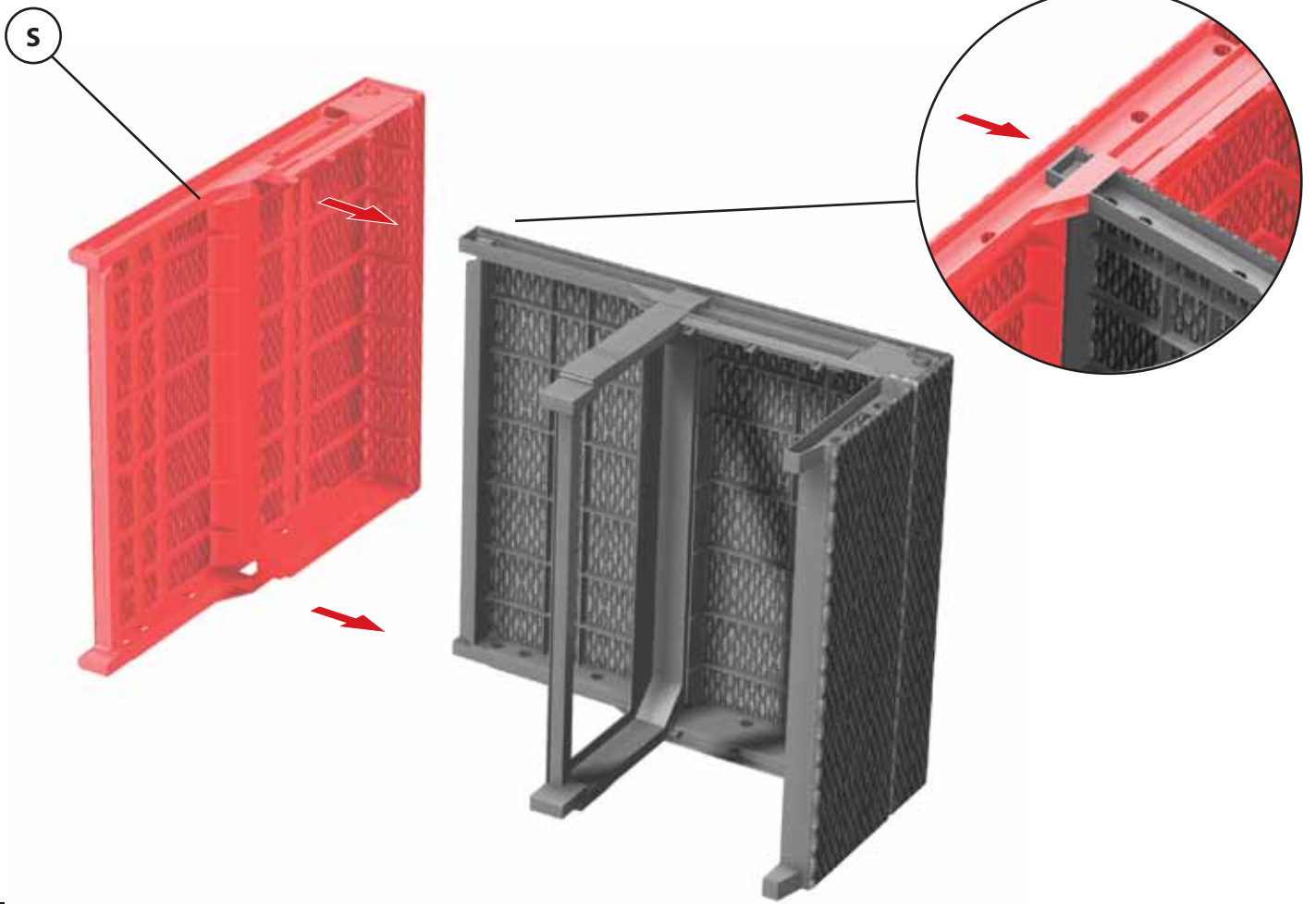

3

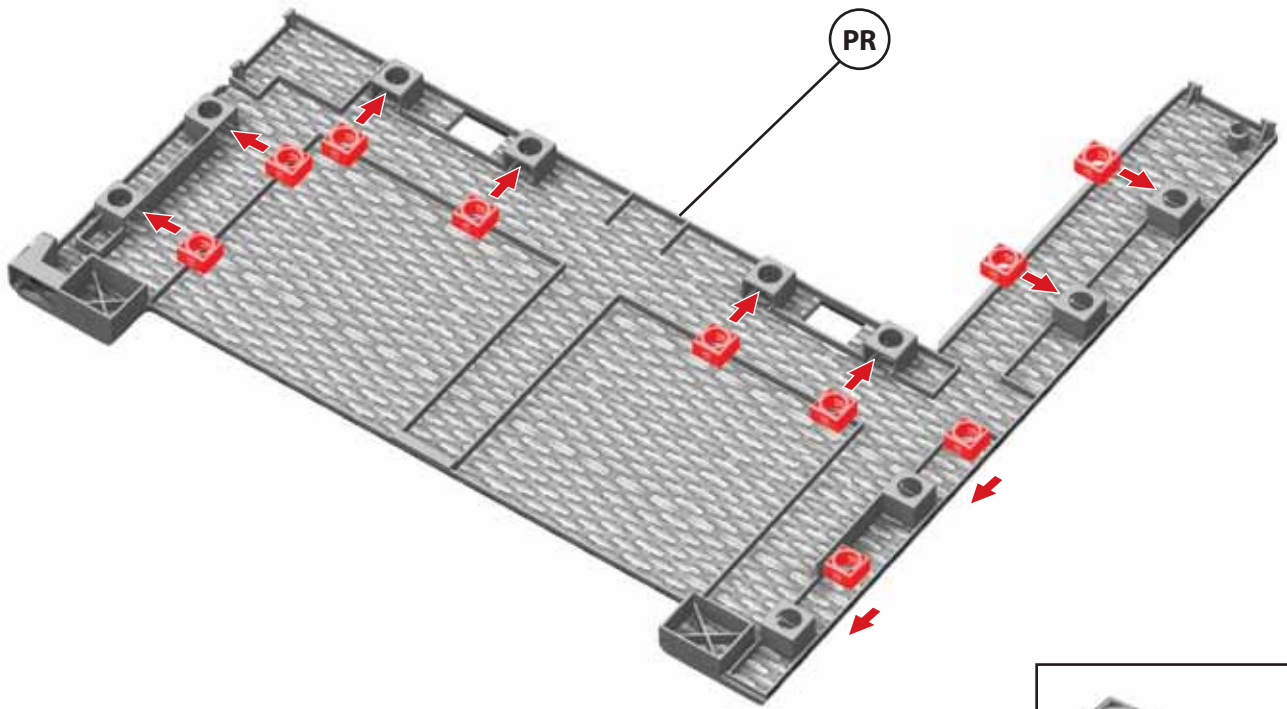

4

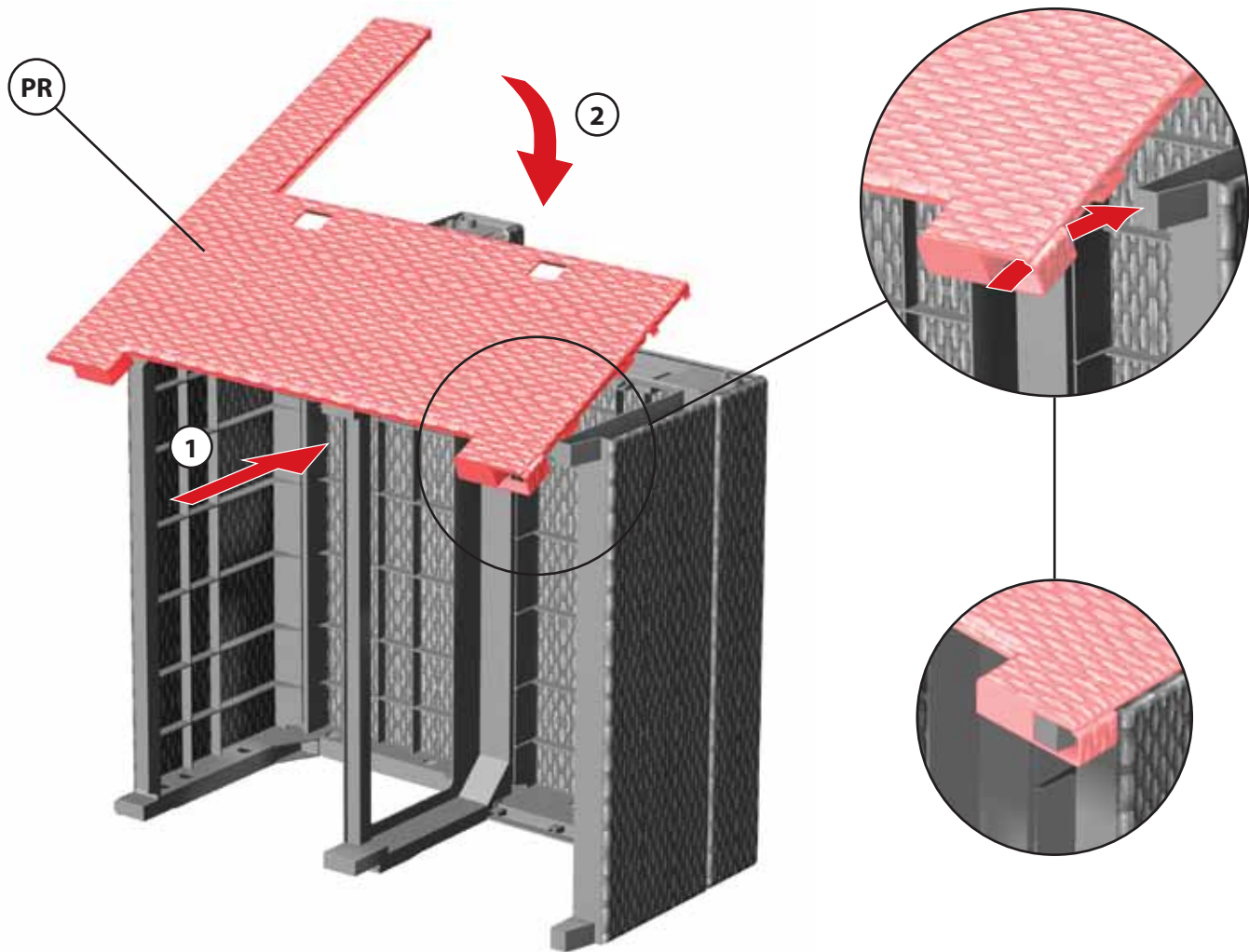

5

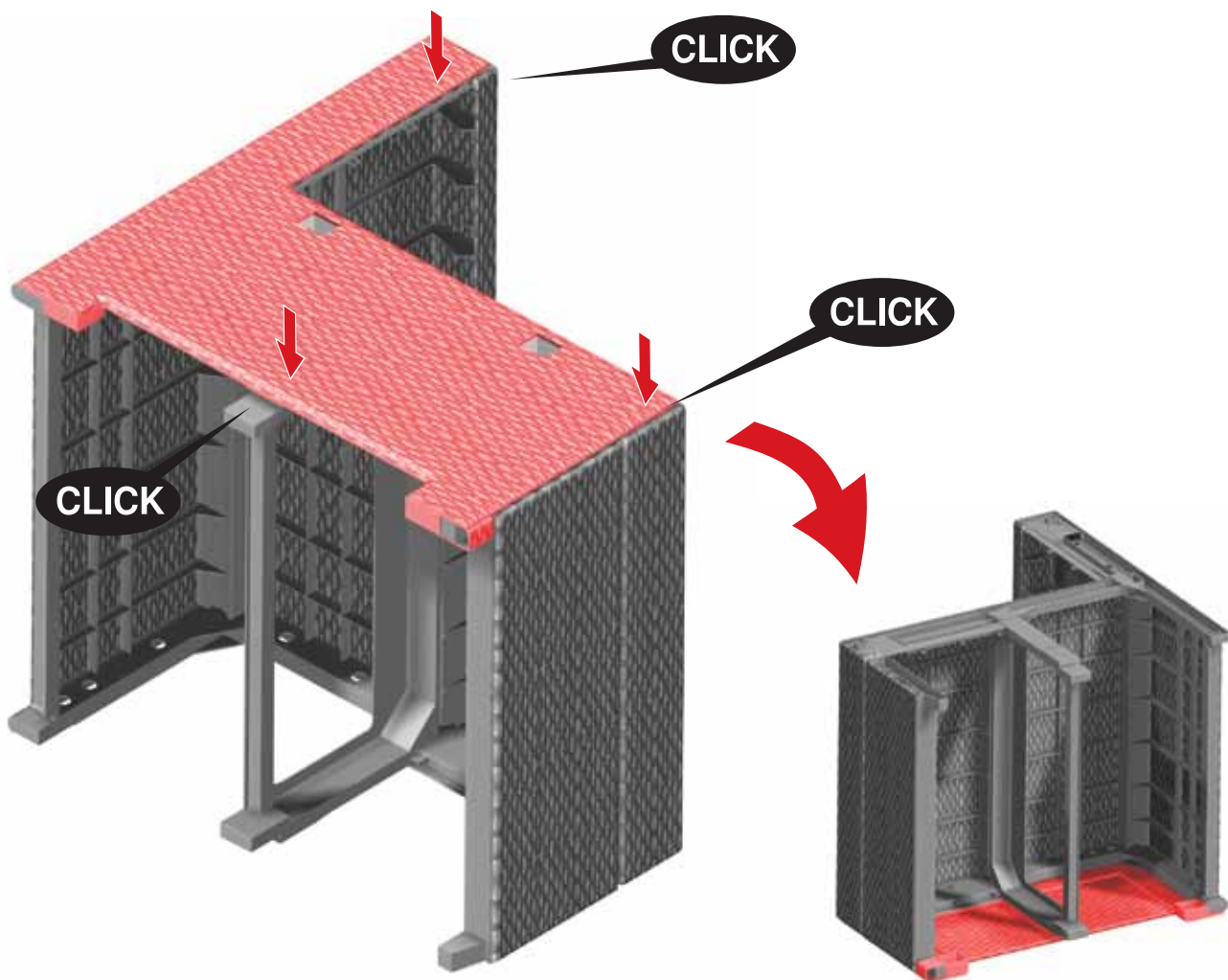

6

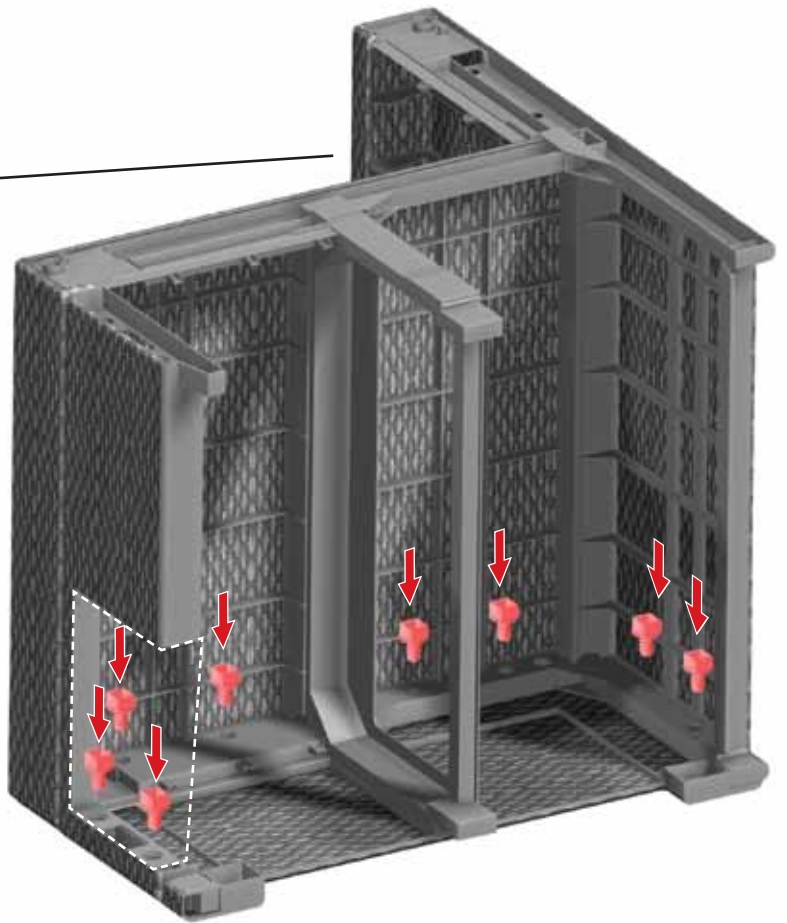
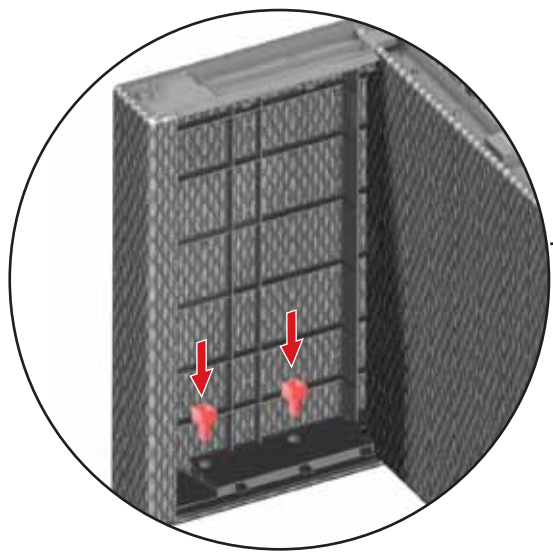

7

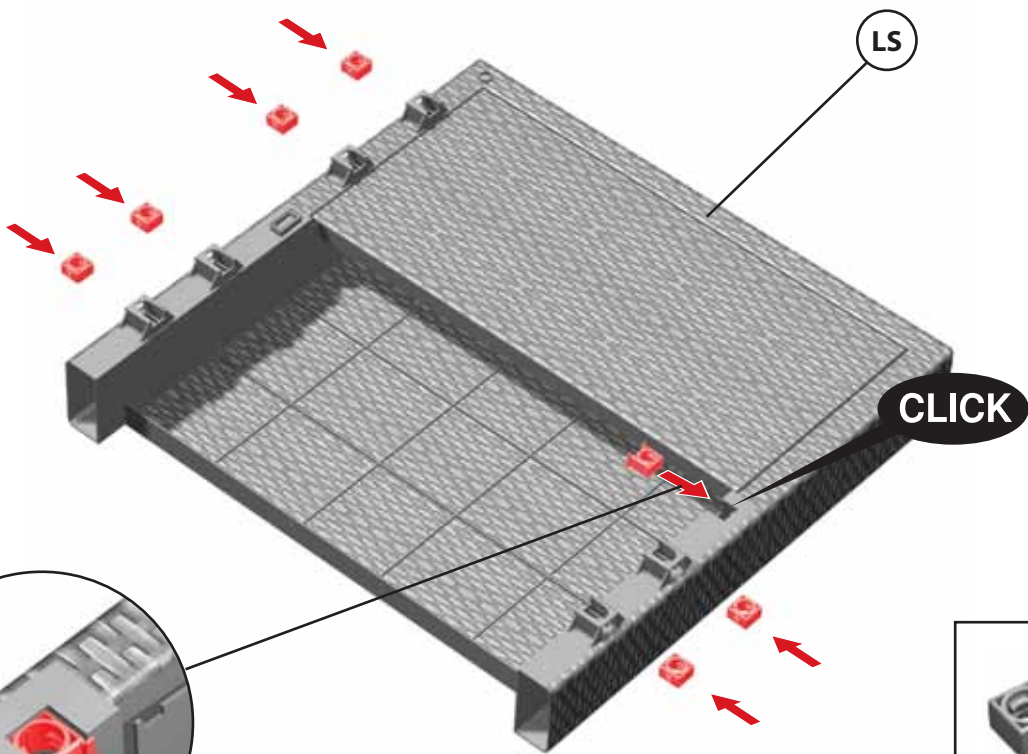

8

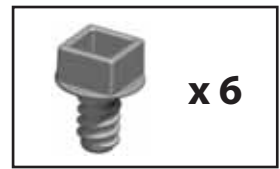
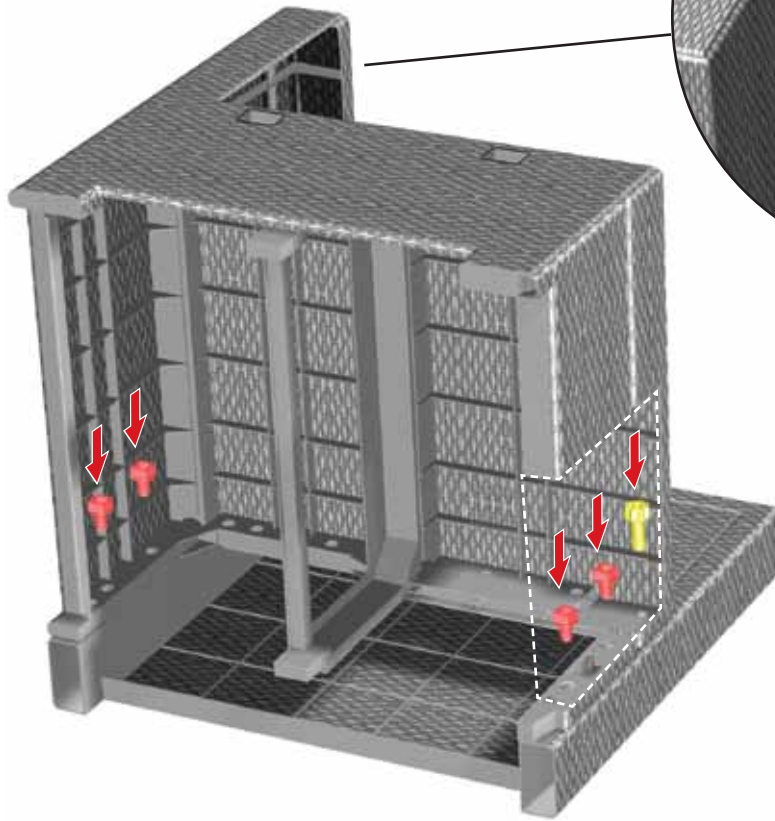
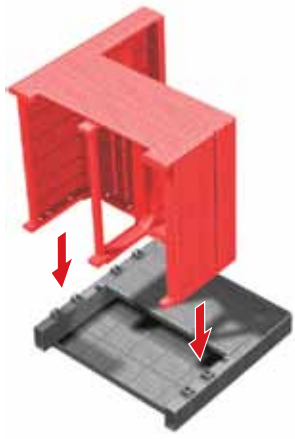

9

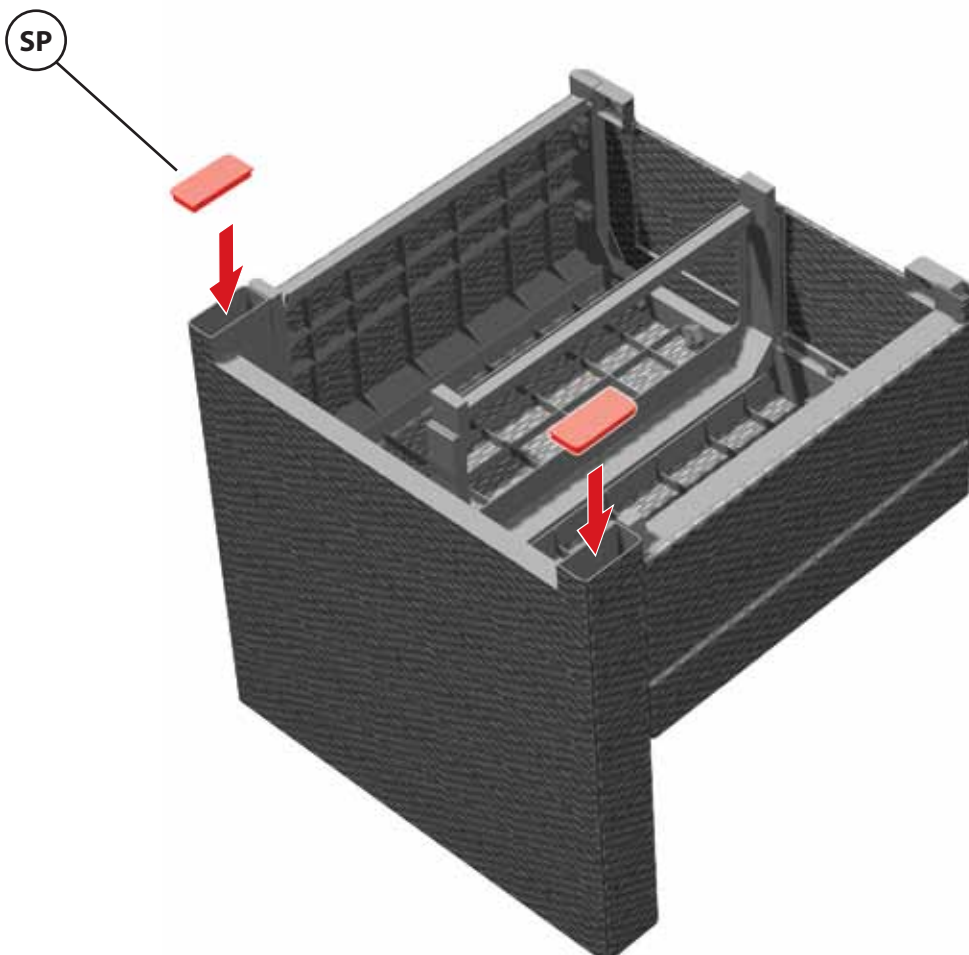

10

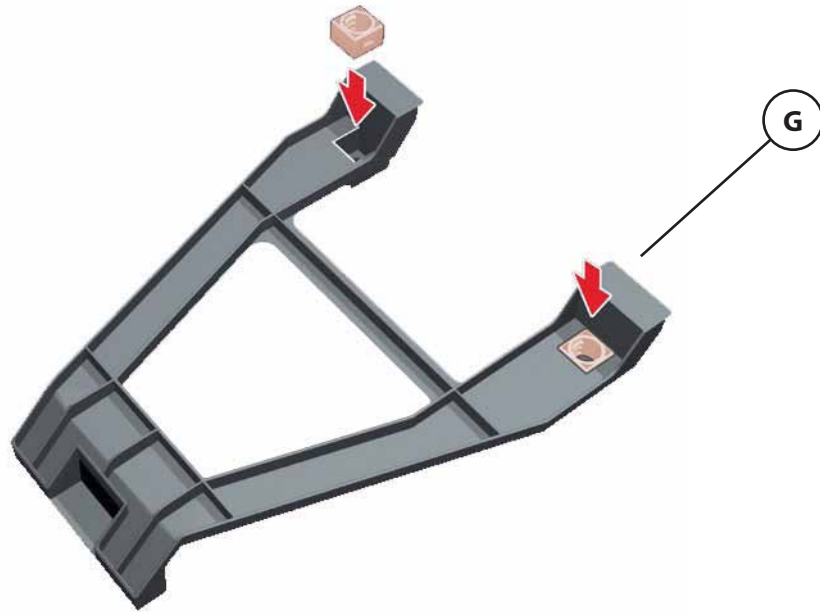
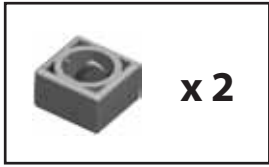

11

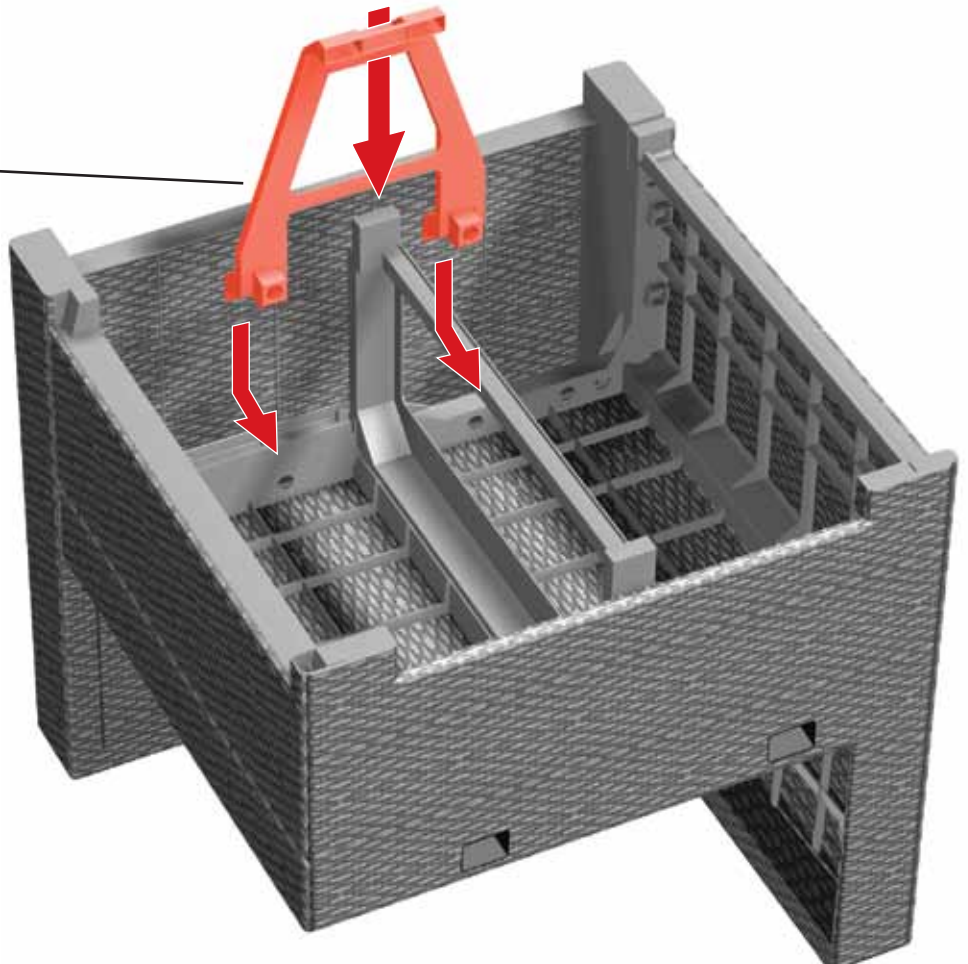

12

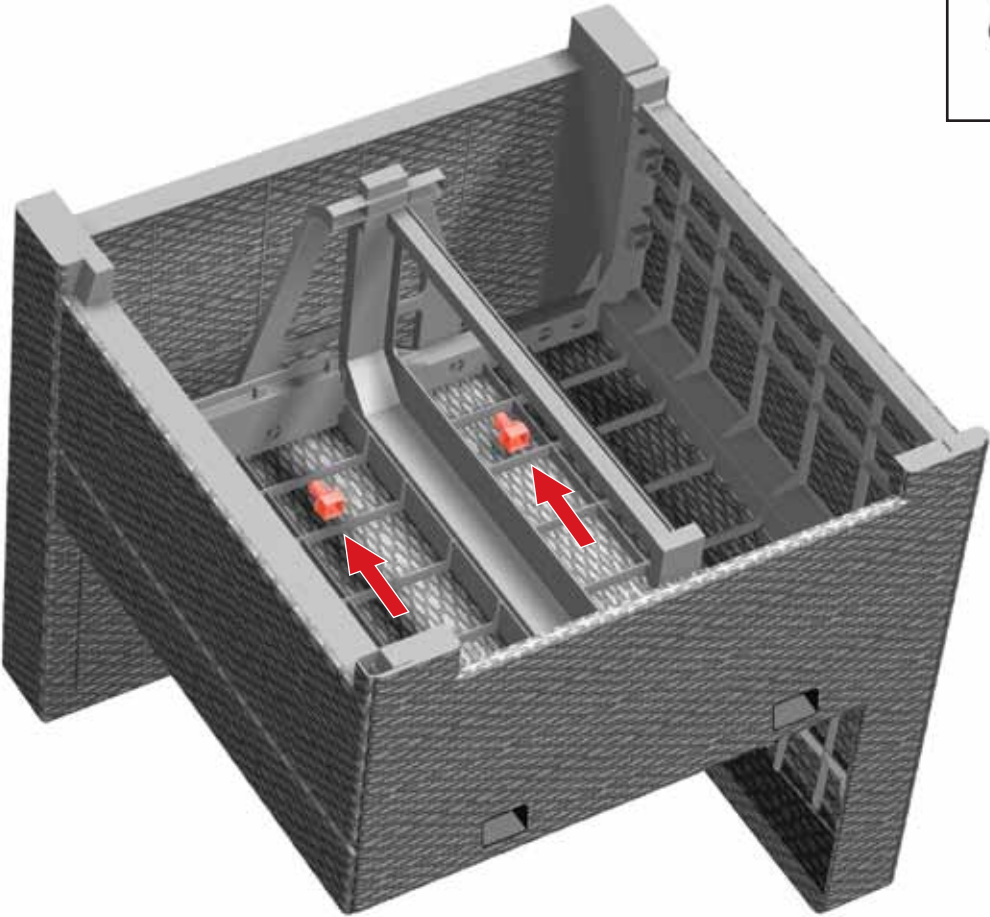

13

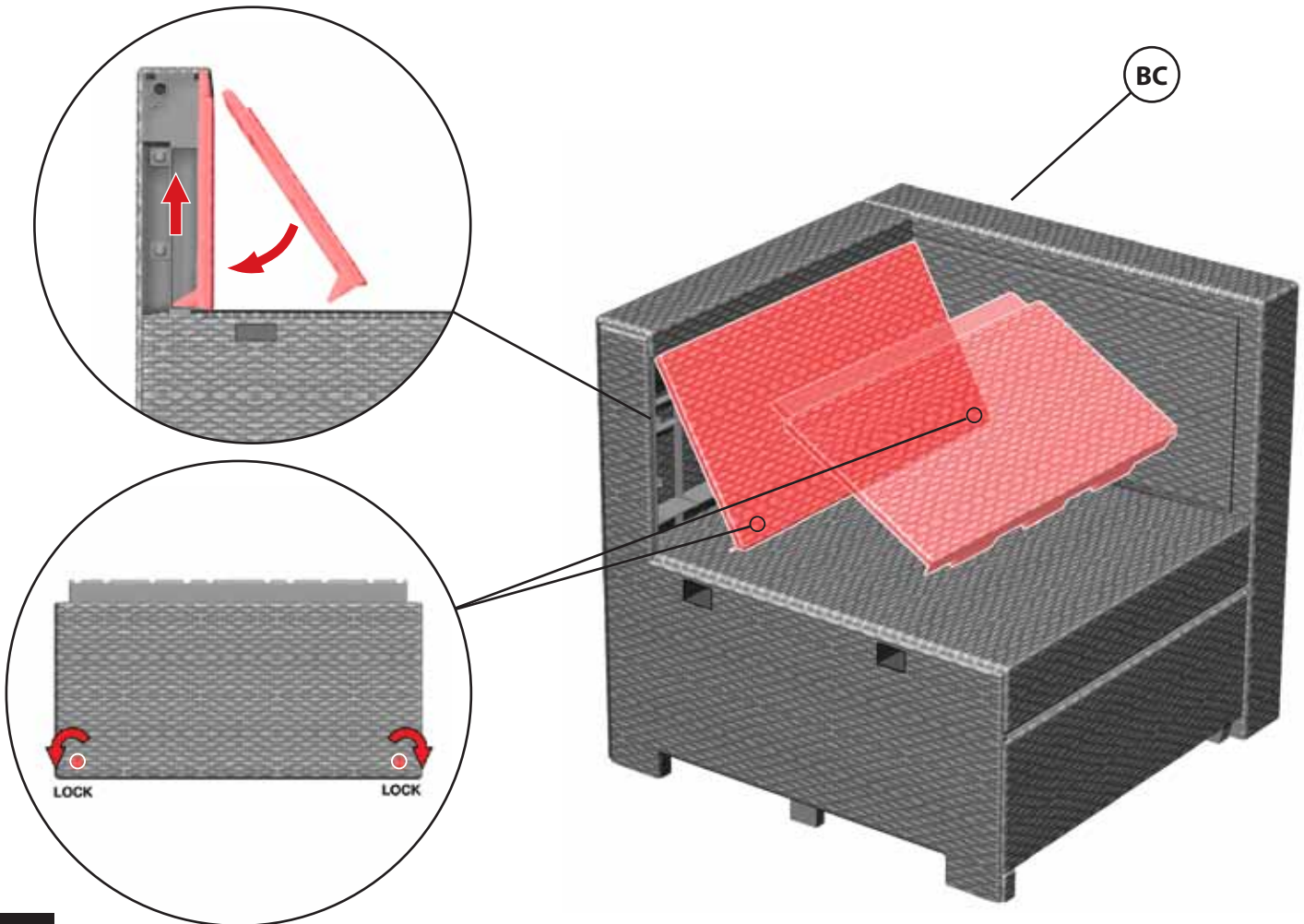

14

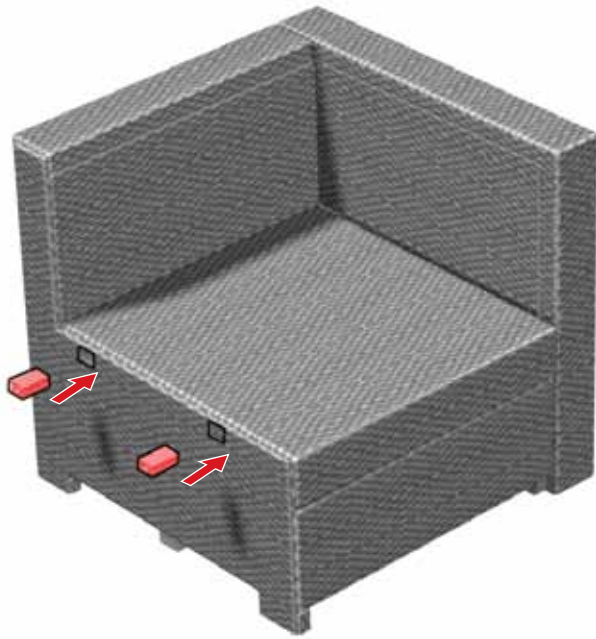

1

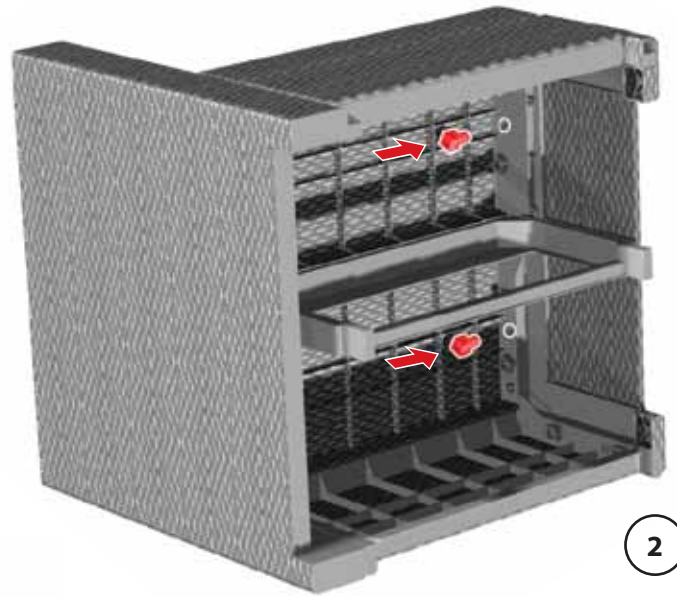
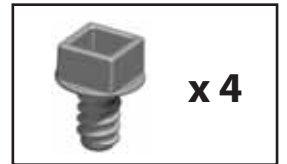

2

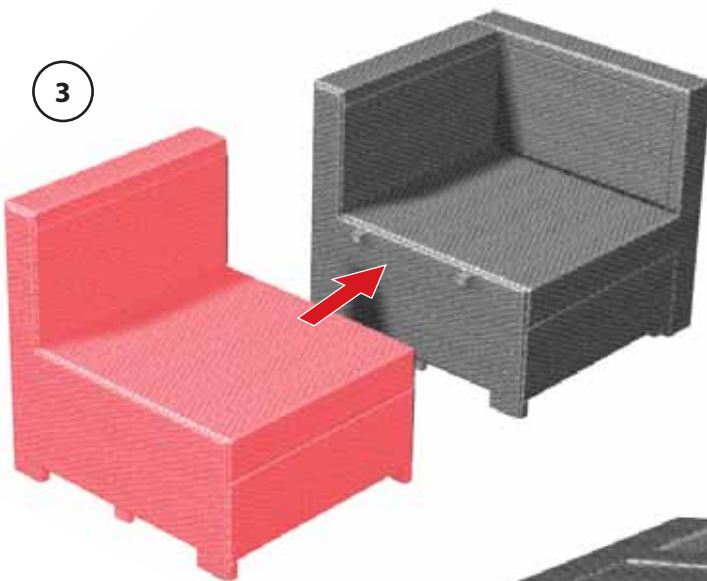

3

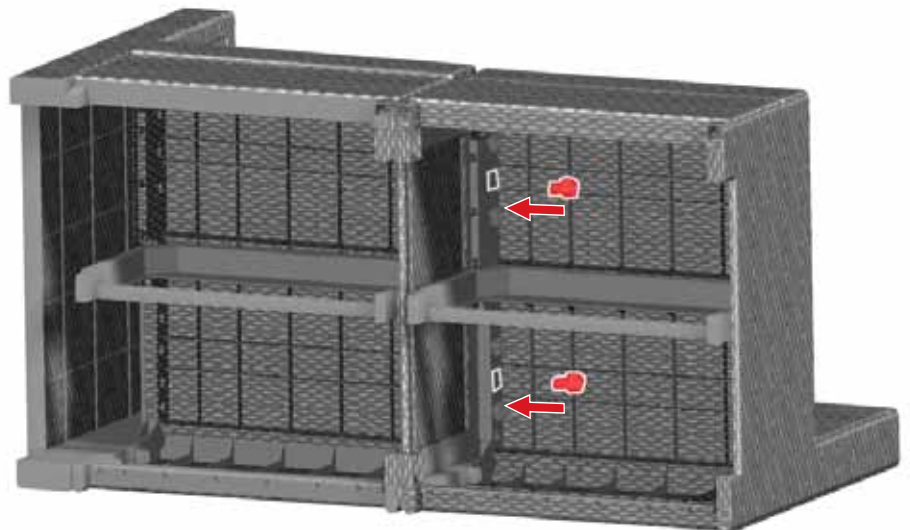

4

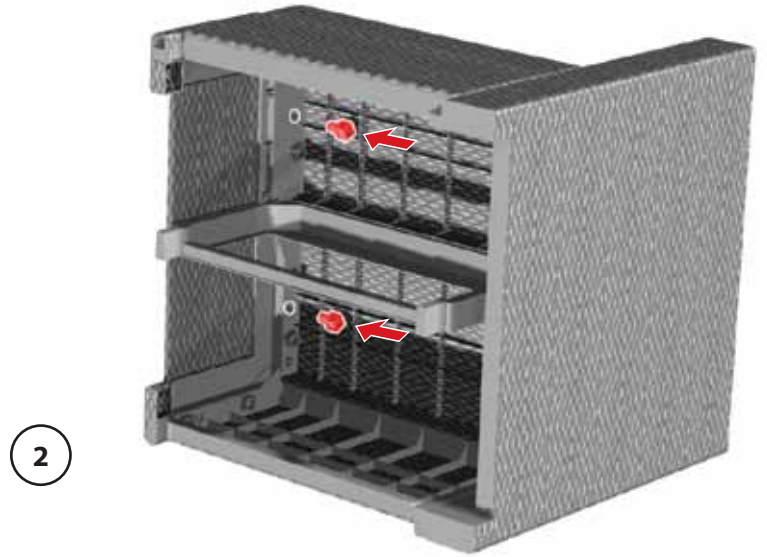
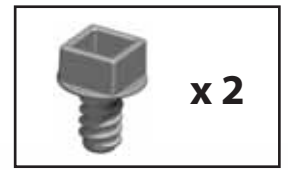
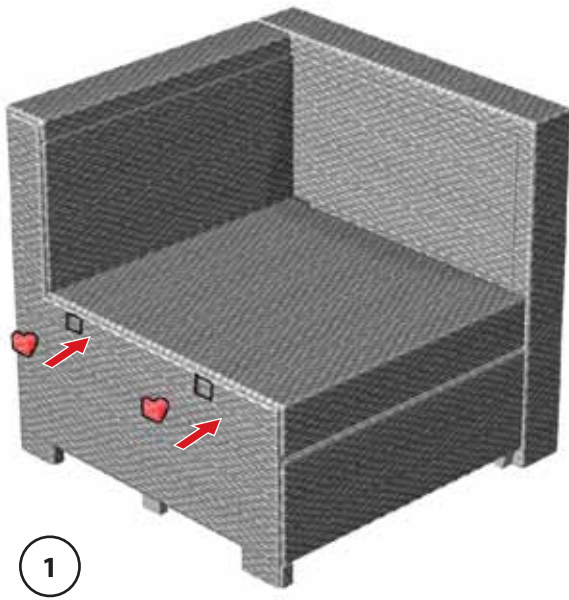



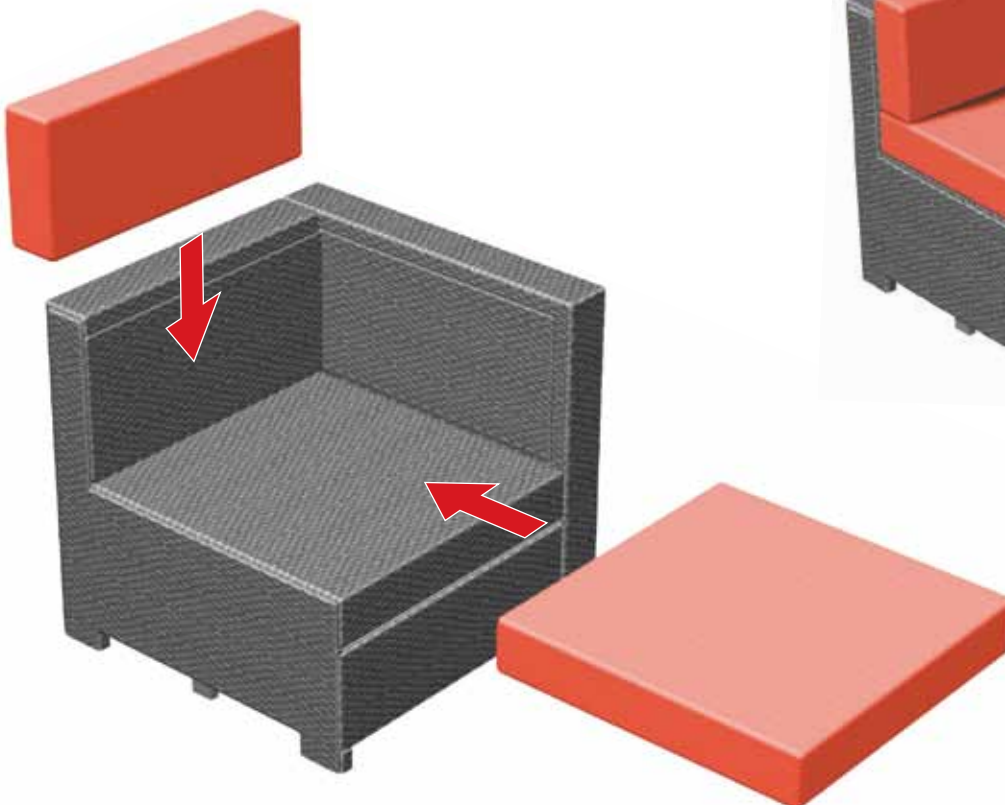





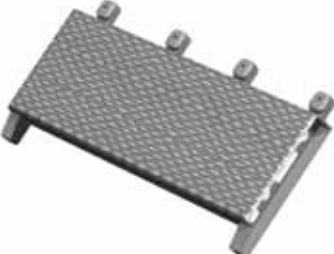
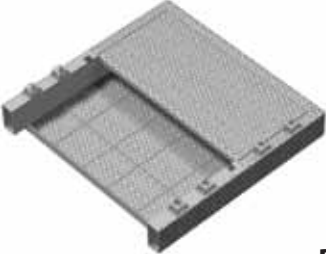
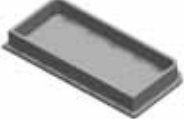

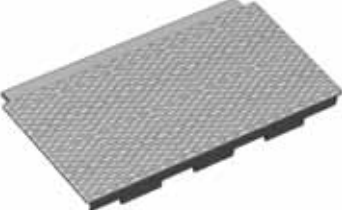

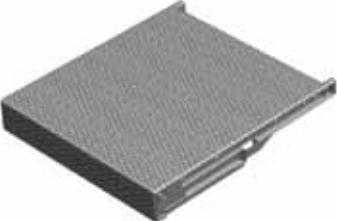

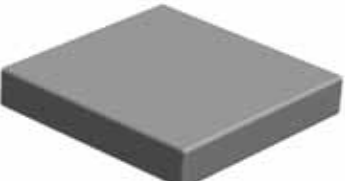

15B

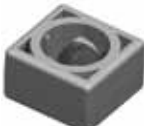

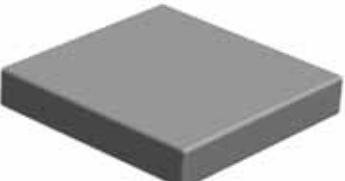
16



 <p>F x1</p>	 <p>RS x1</p>	 <p>SP x2</p>	 <p>G x1</p>
 <p>PL x1</p>	 <p>BC x1</p>	 <p>x4</p>	 <p>x1</p>
 <p>S x2</p>	 <p>L x1</p>	 <p>x1</p>	 <p>x20</p>
 <p>x1</p>	 <p>x1</p>	 <p>x18</p>	 <p>x1</p>
 <p>x1</p>	 <p>x1</p>	 <p>x1</p>	 <p>x2</p>

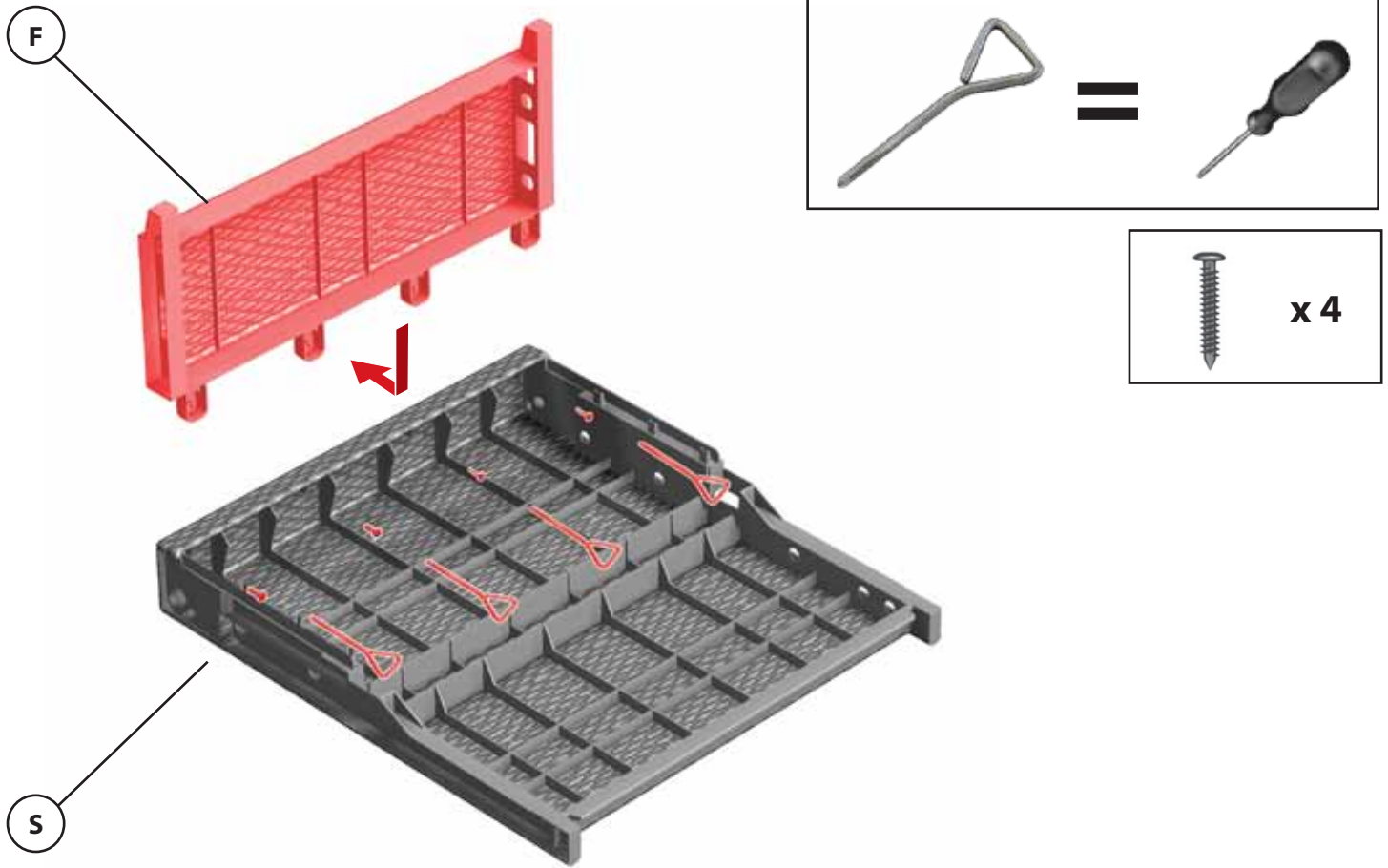

1

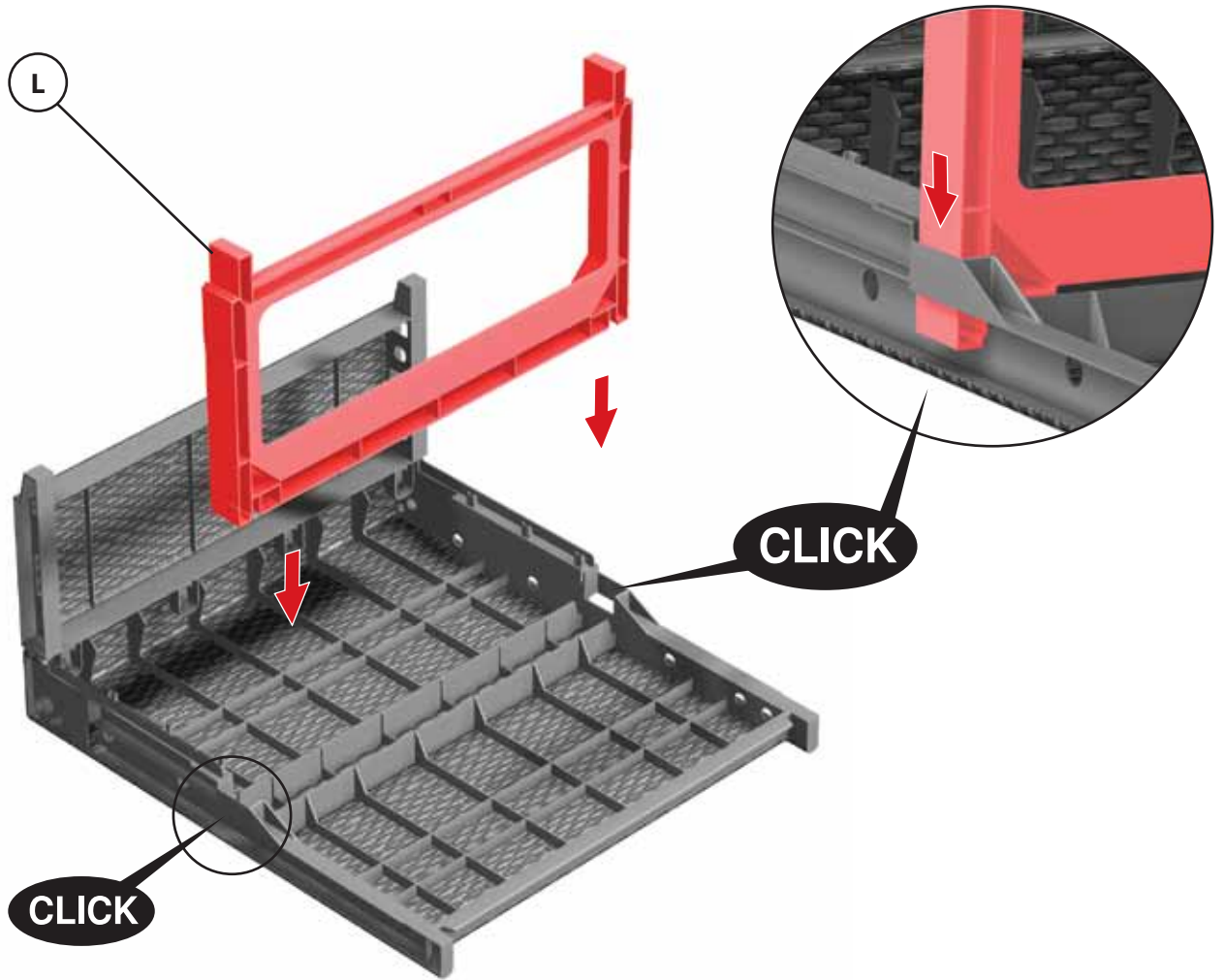

2

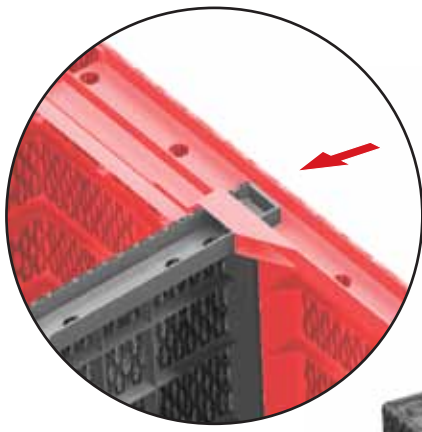

3

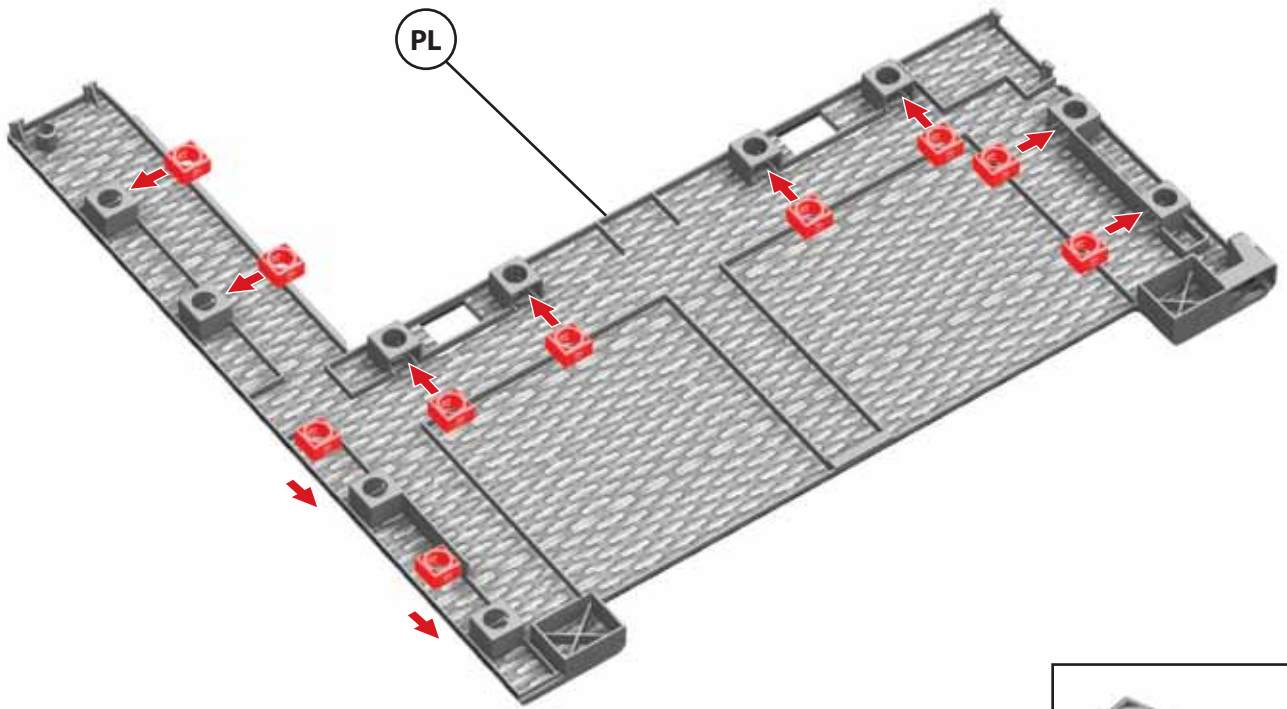

4

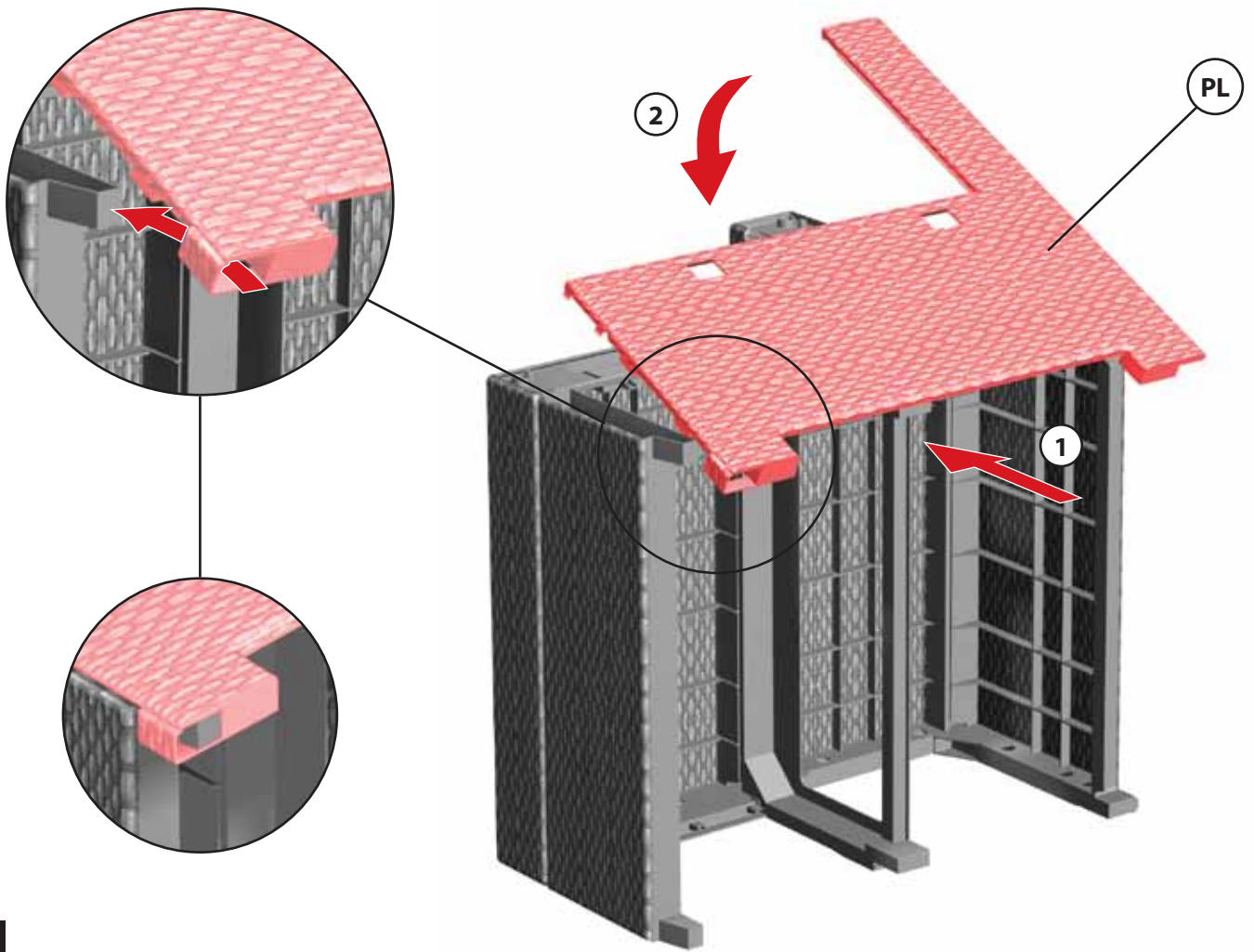

5

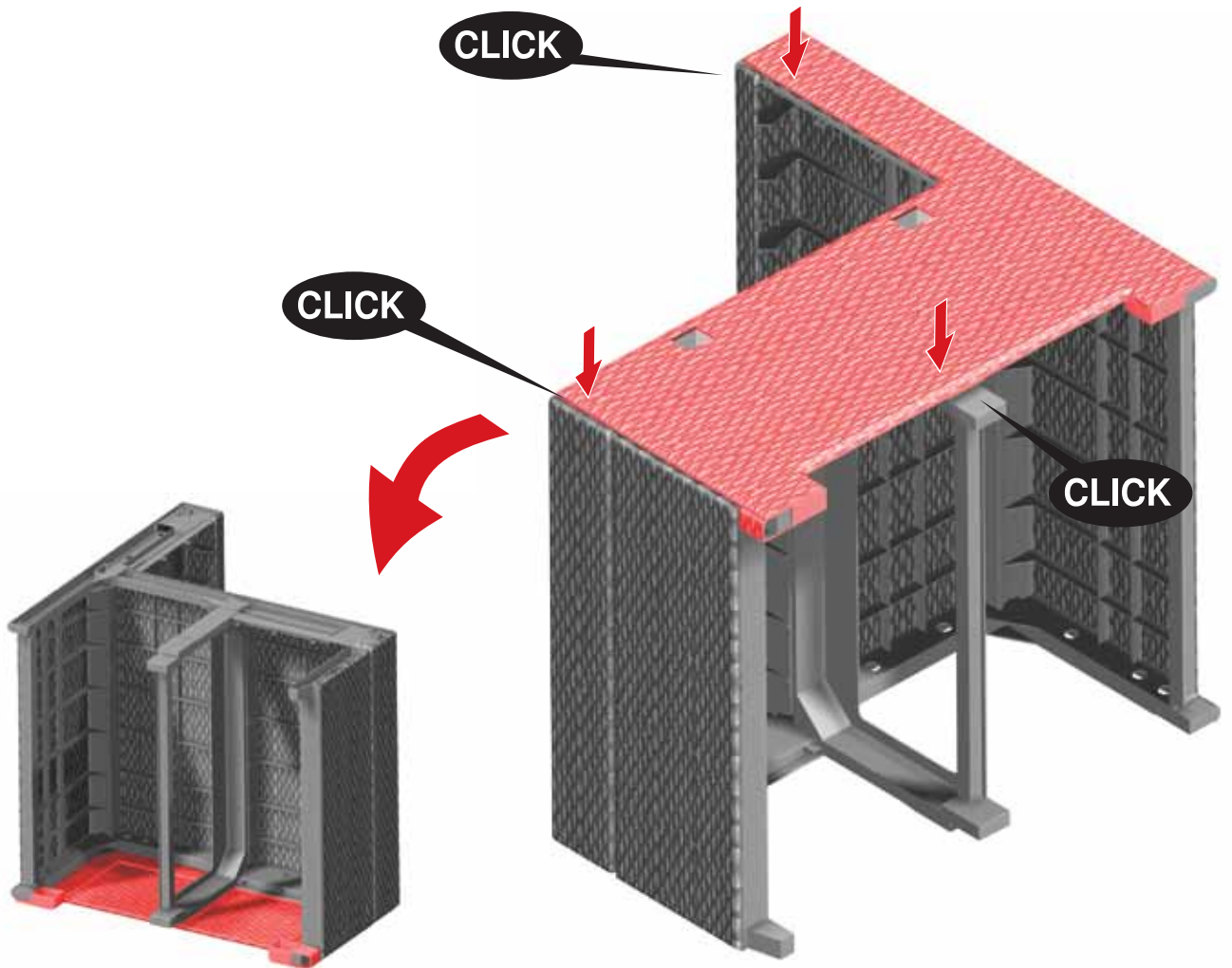

6

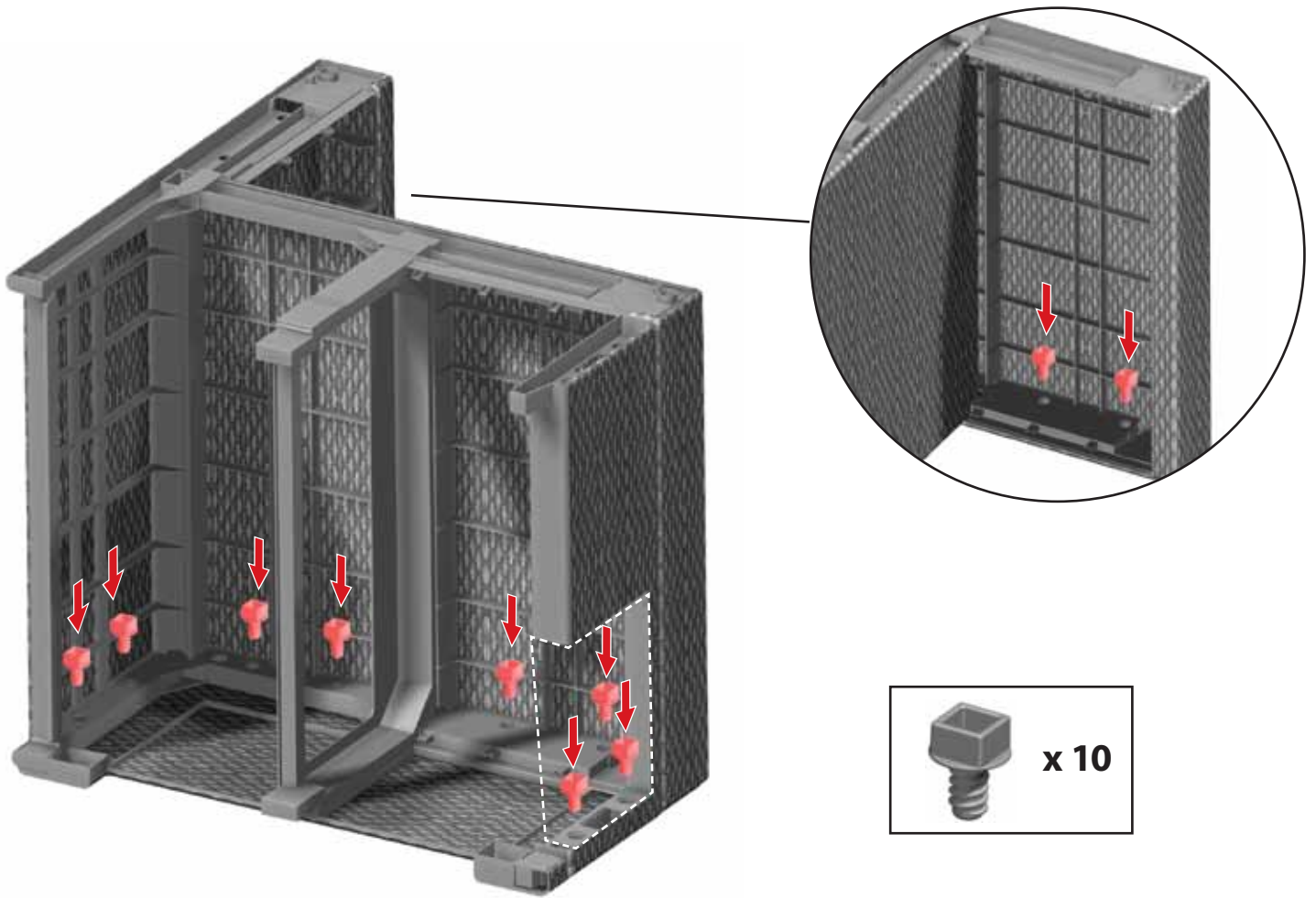

7

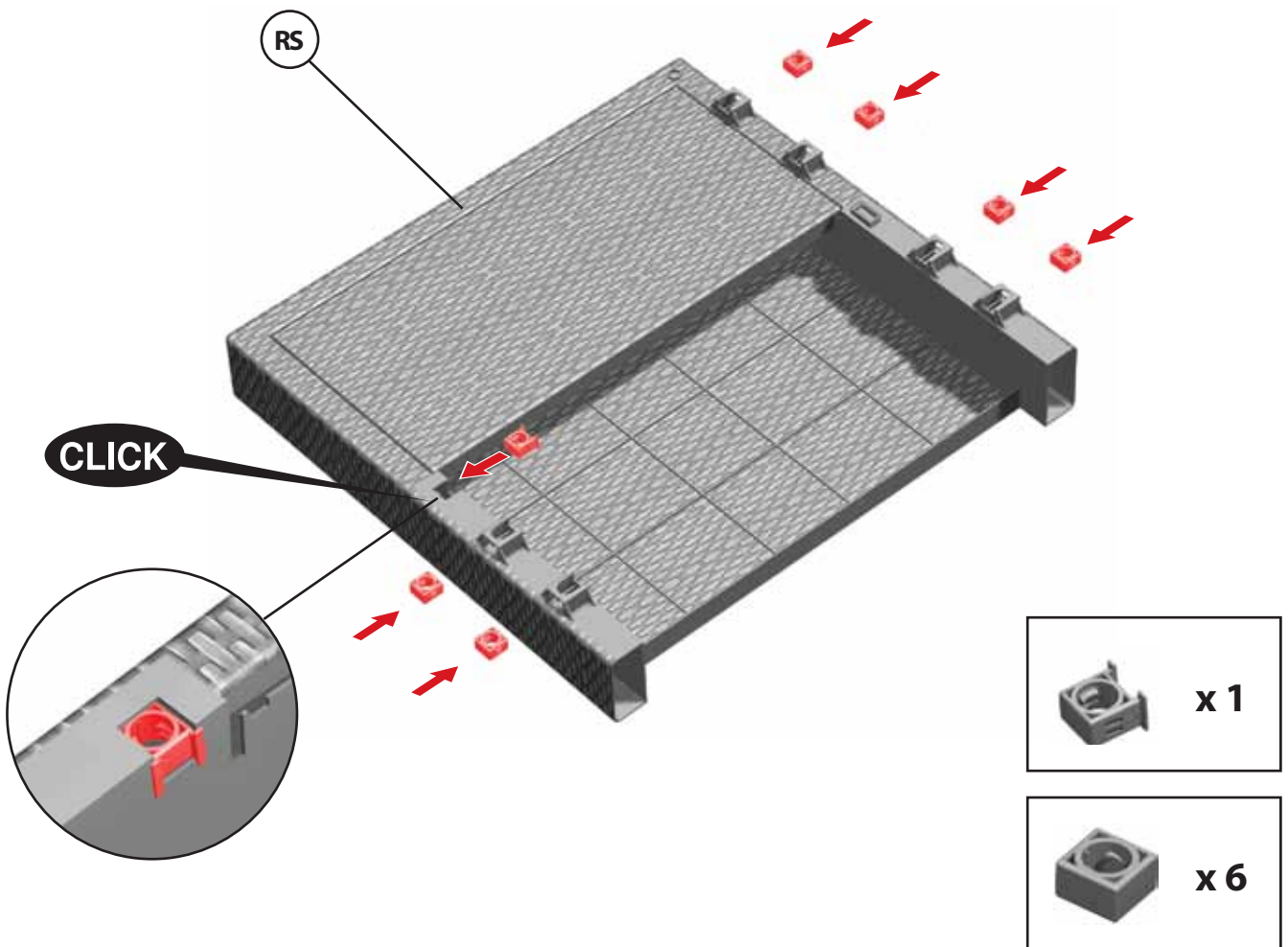

8

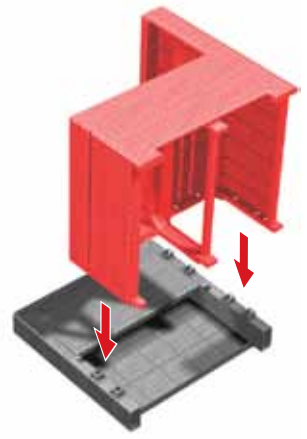
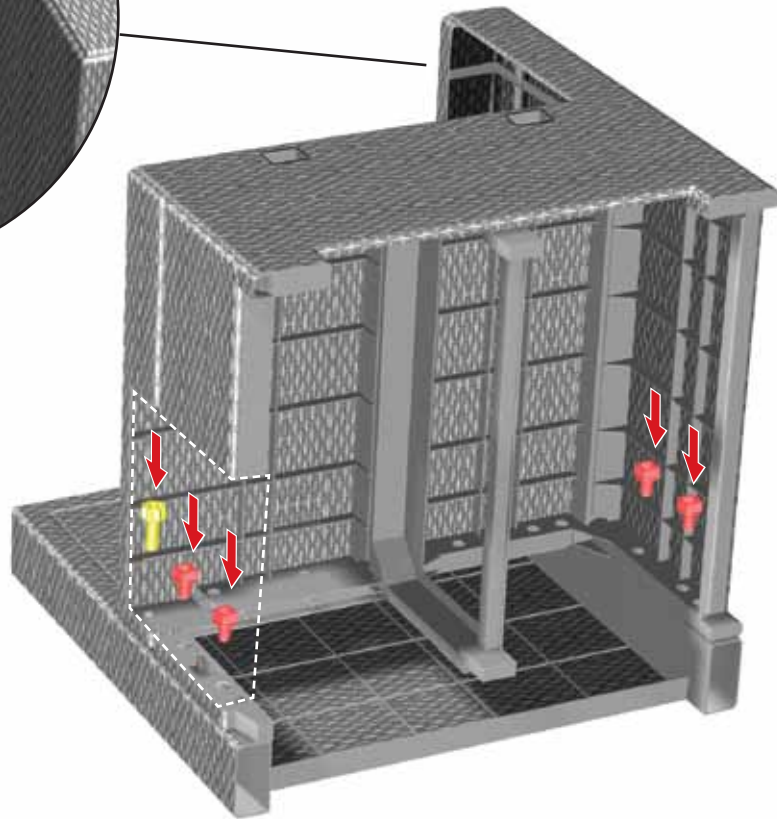
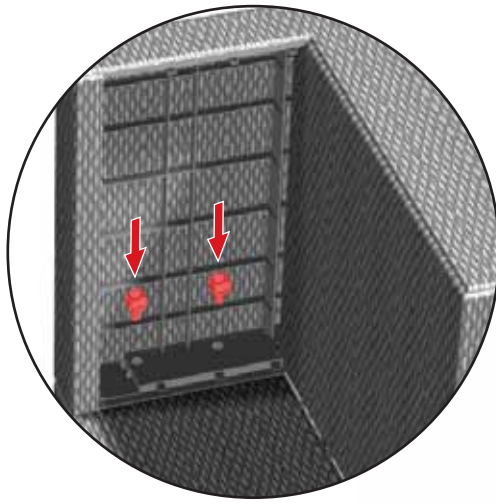

9

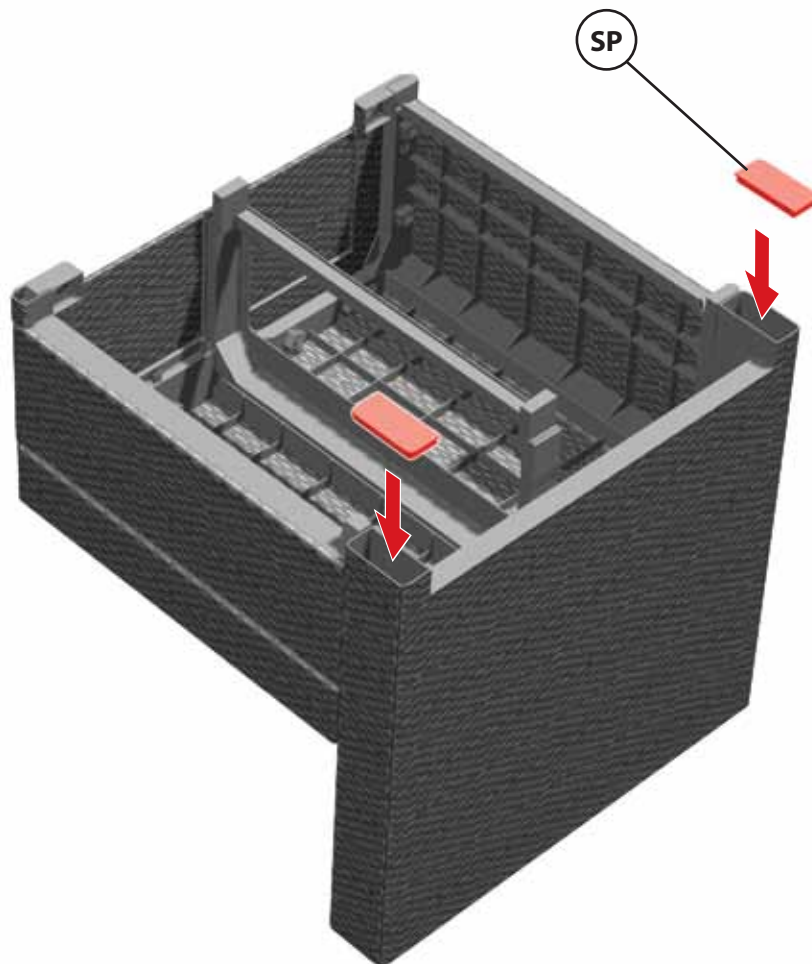

10

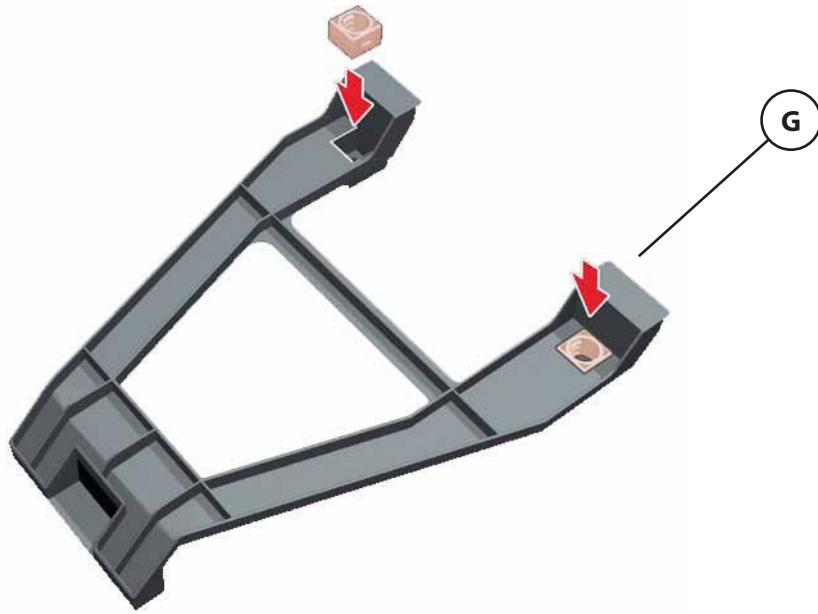
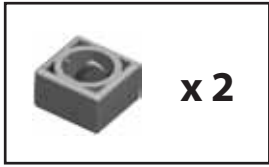

11

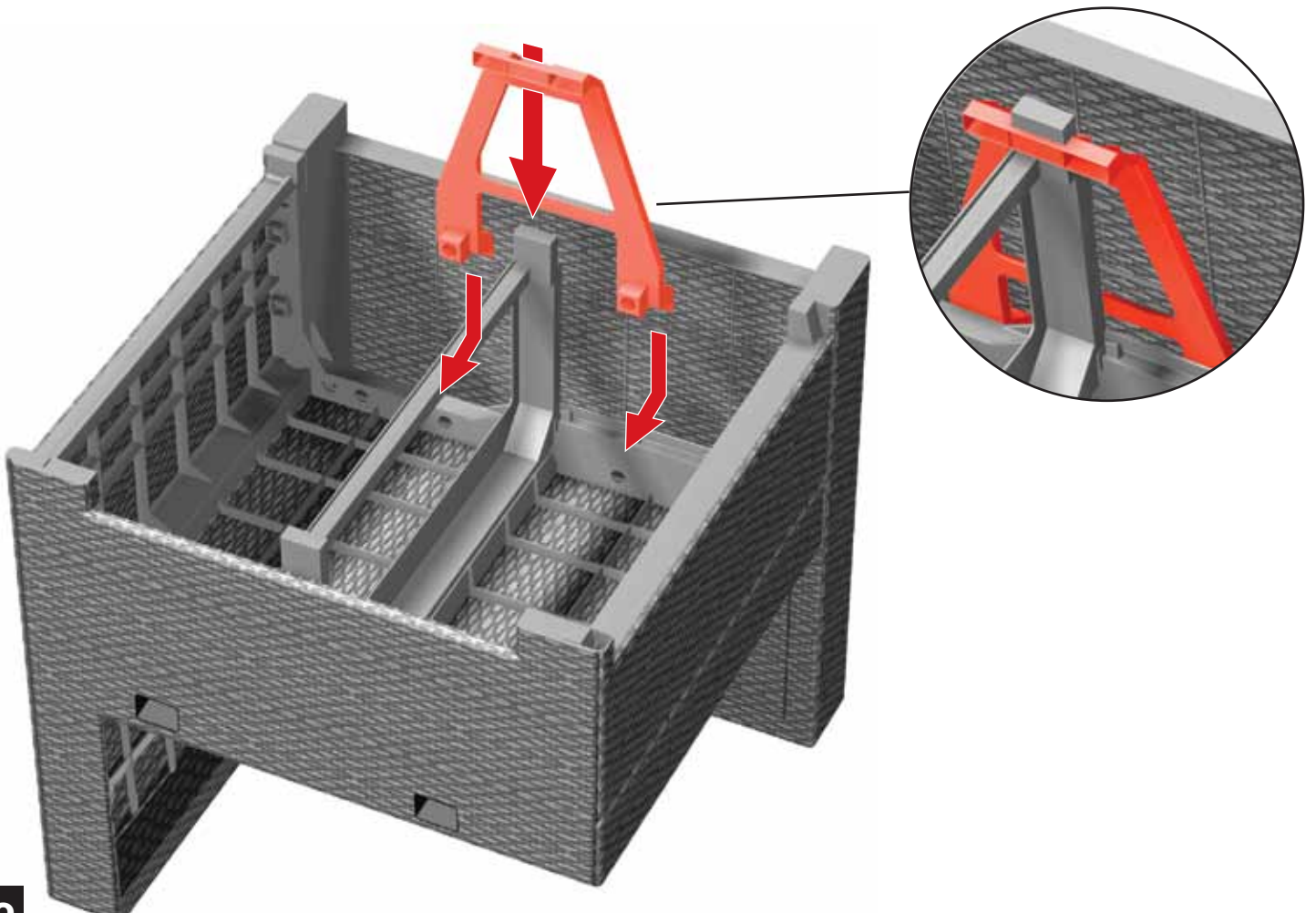

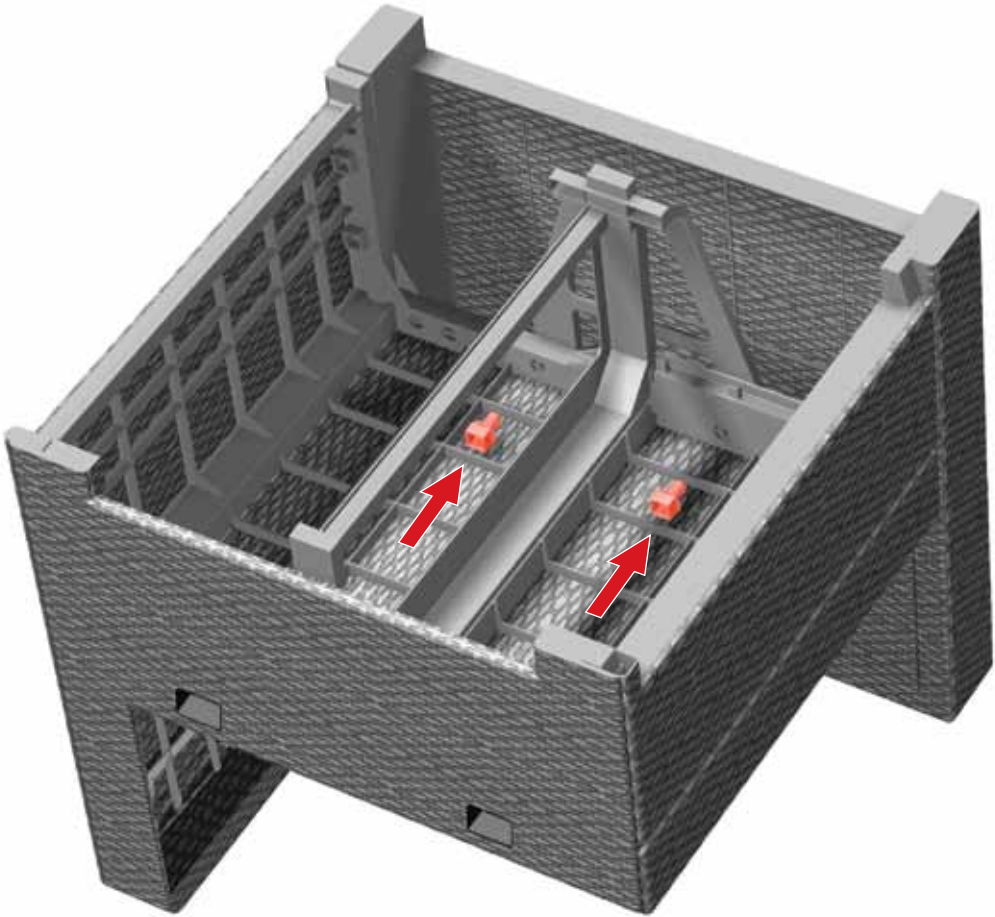

13

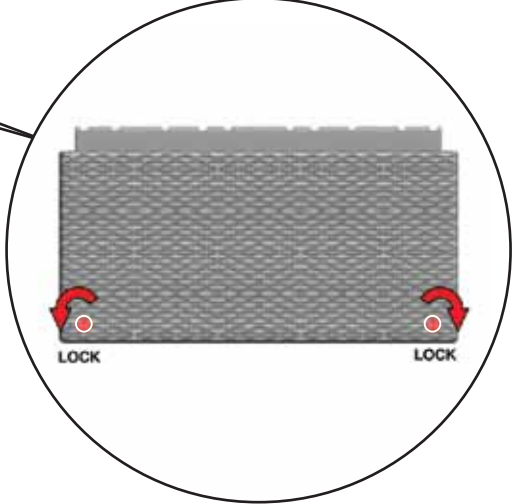
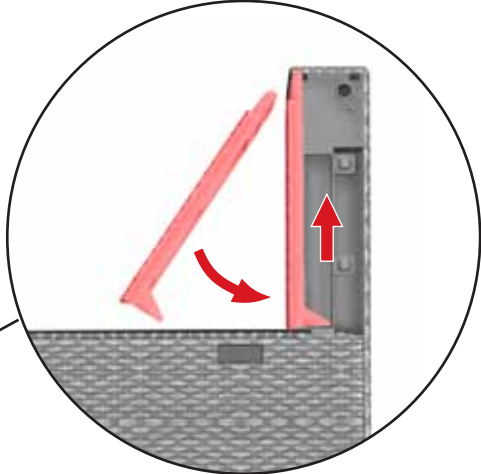
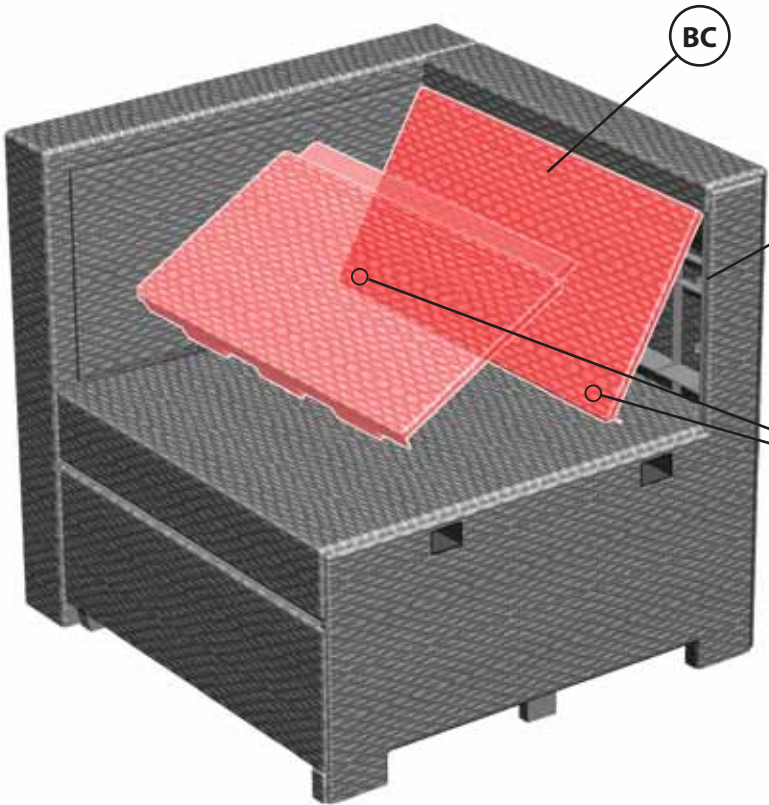

14

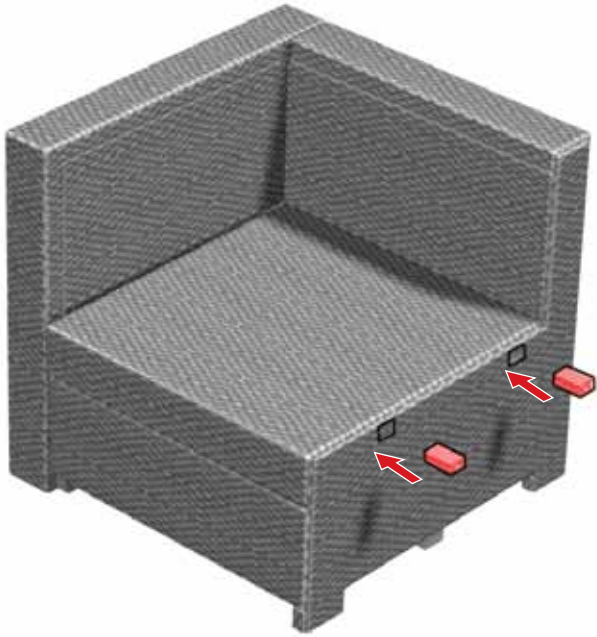

1

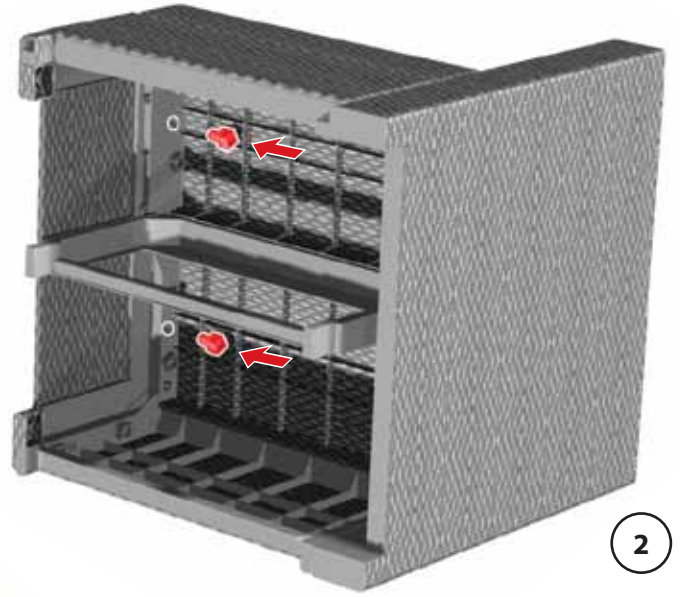
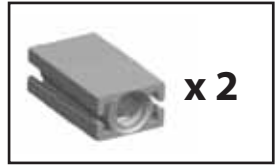
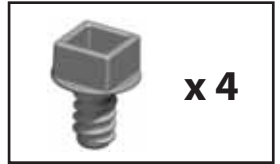

2

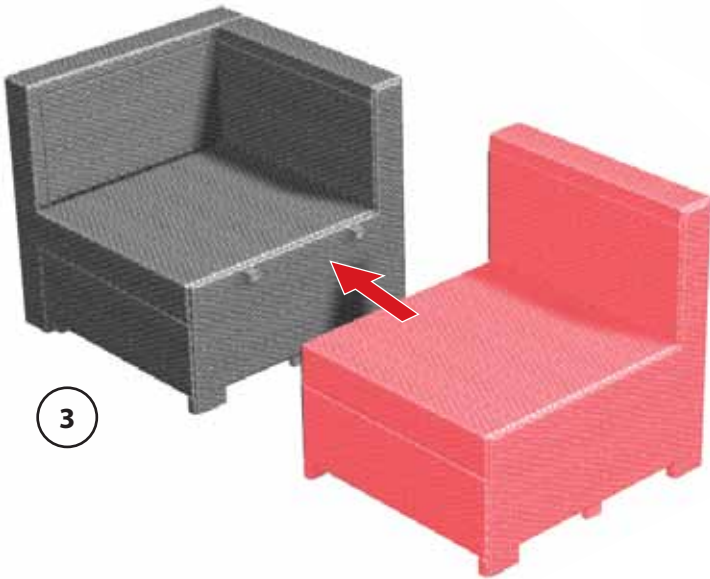

3

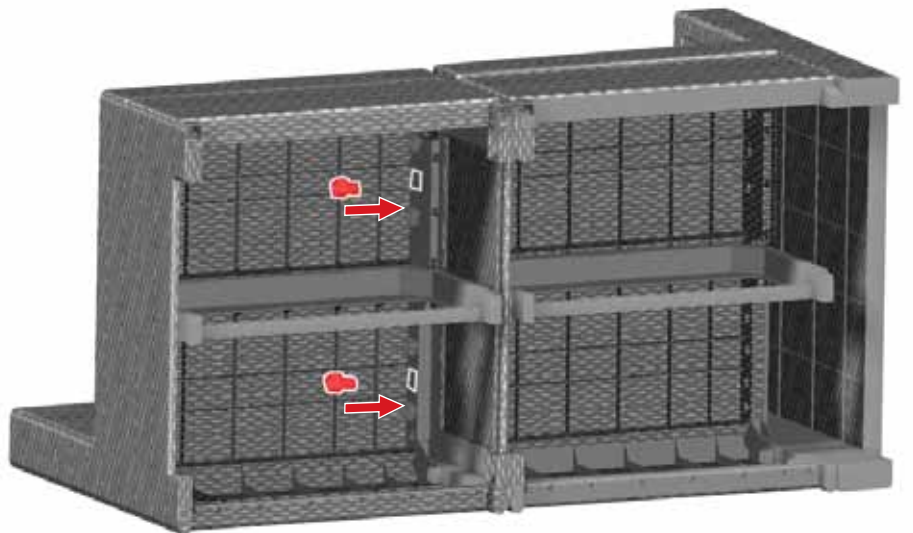

4

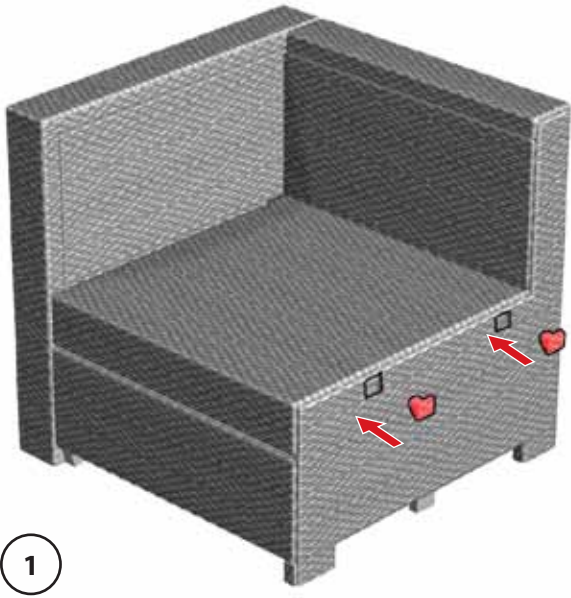

1

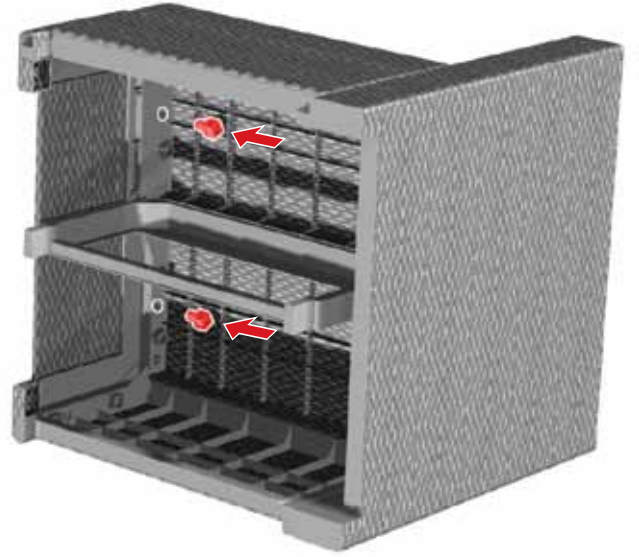





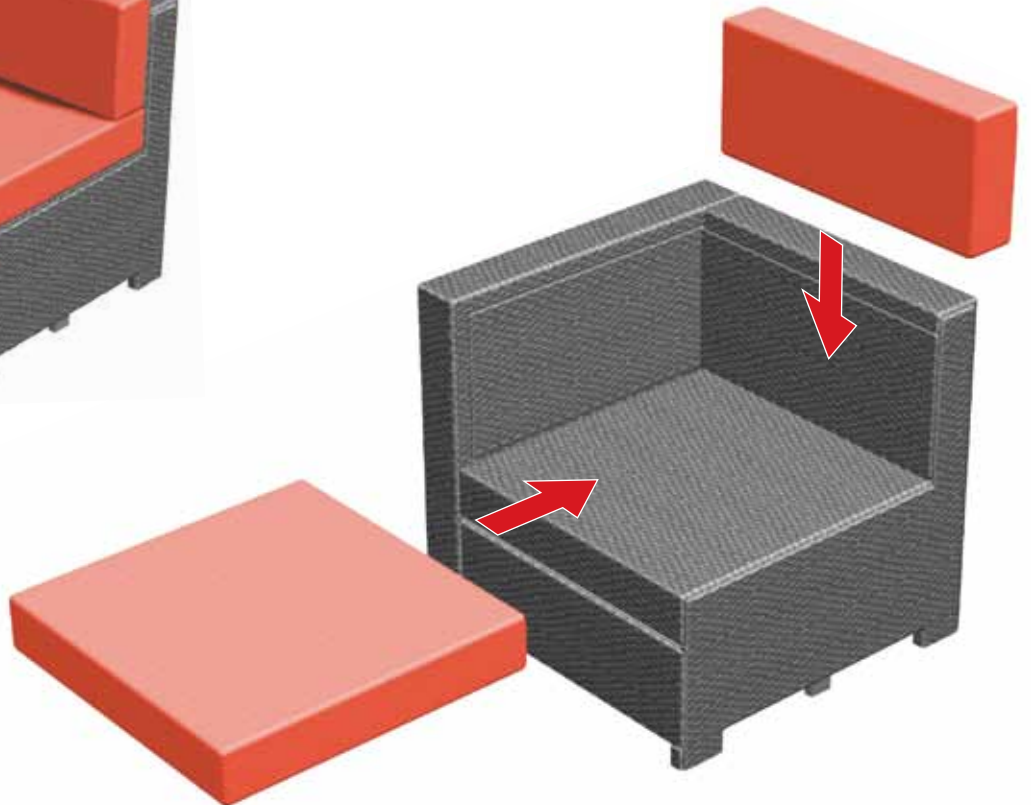



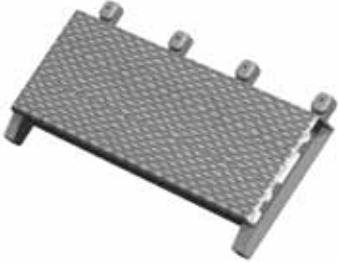
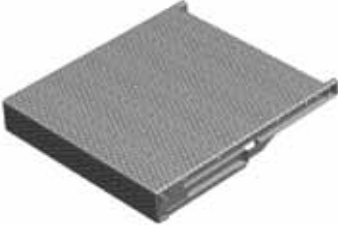

2

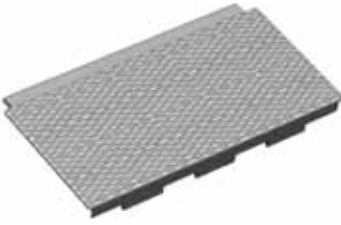
15B

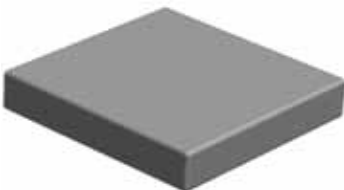

16

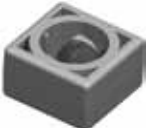

 <p>F x1</p>	 <p>S x2</p>	 <p>x4</p>
 <p>PR x1</p>	 <p>BC x1</p>	 <p>x1</p>
 <p>PL x1</p>	 <p>L x1</p>	 <p>x24</p>
 <p>x1</p>	 <p>x1</p>	 <p>x20</p>
		 <p>x4</p>
		 <p>x2</p>

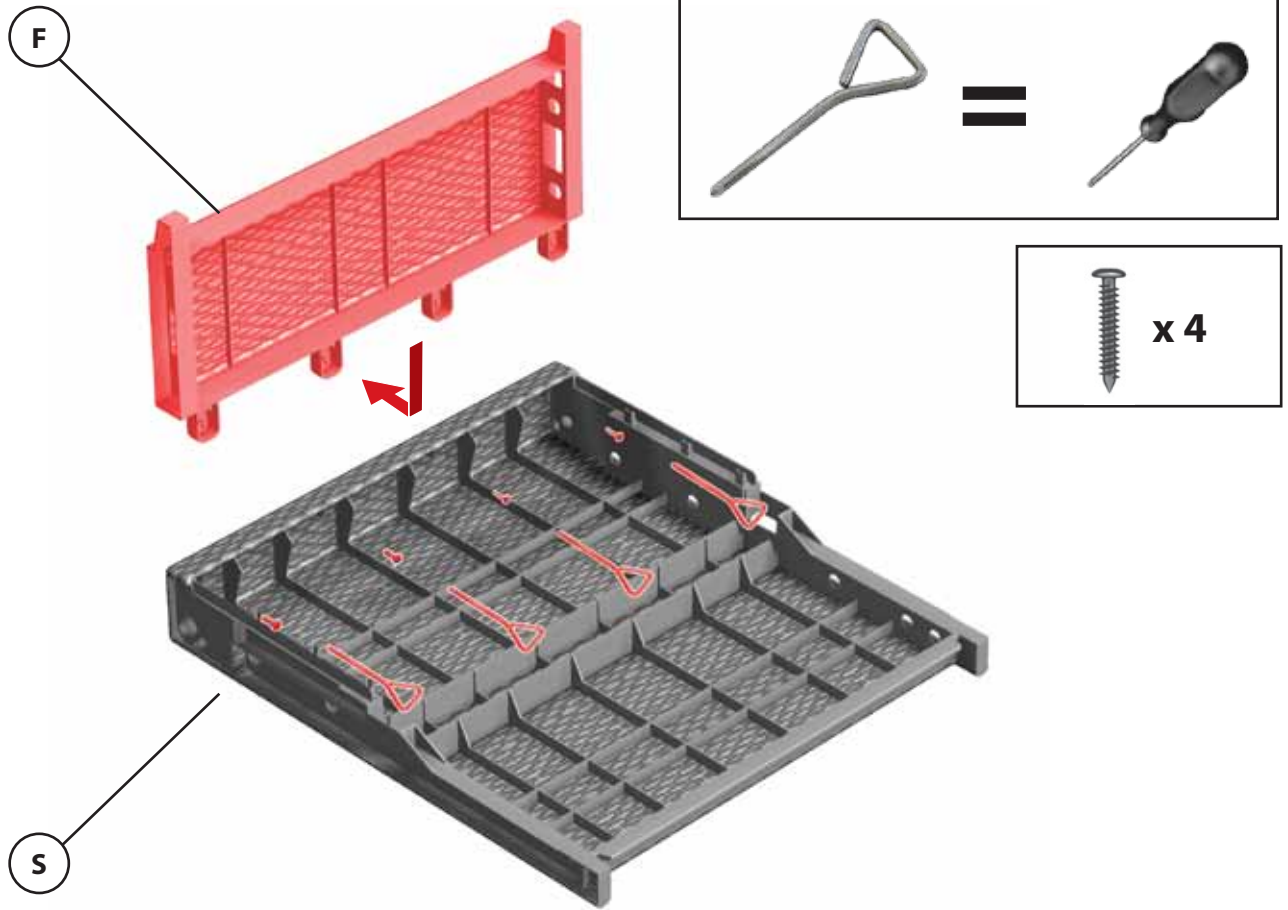

1

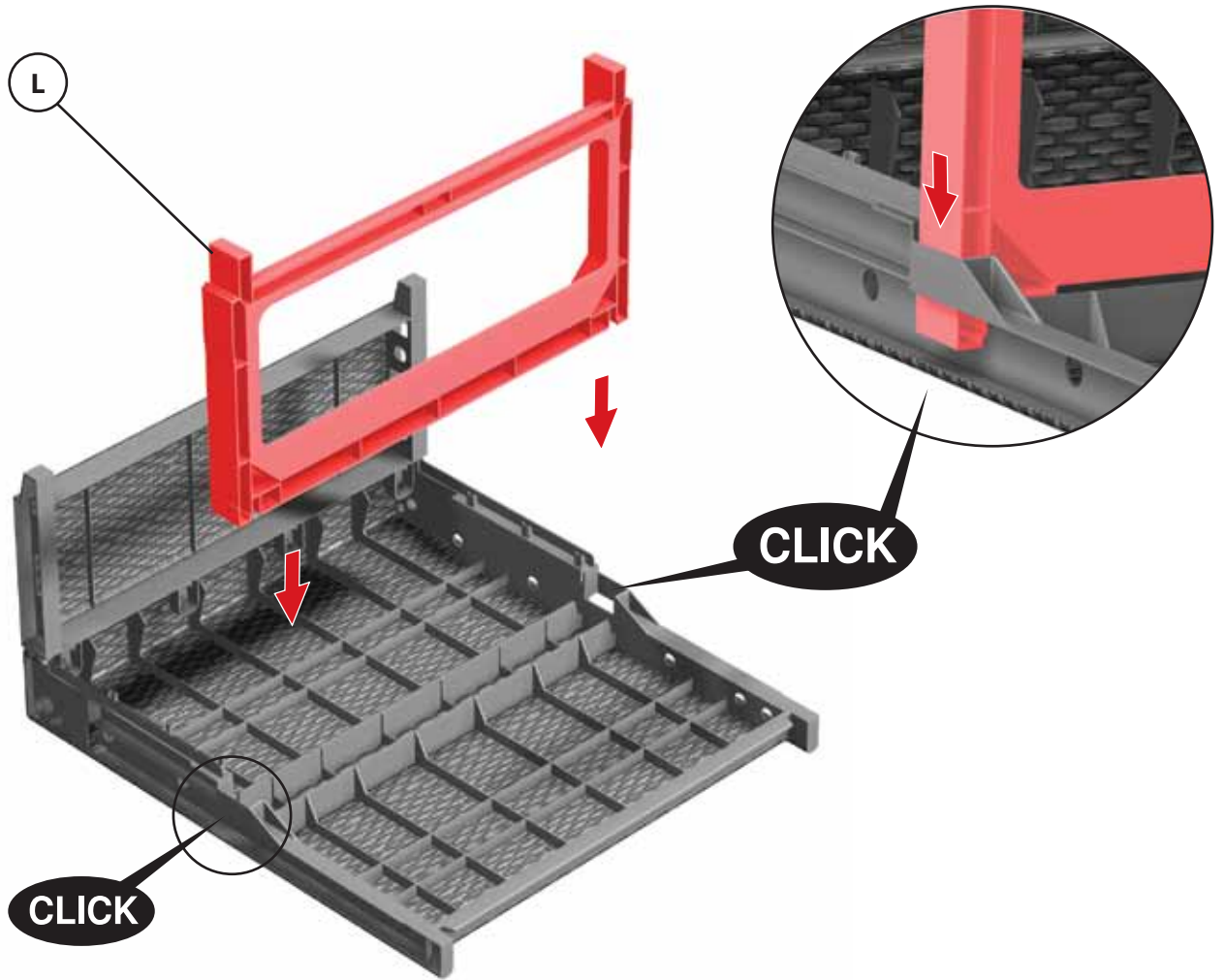

2

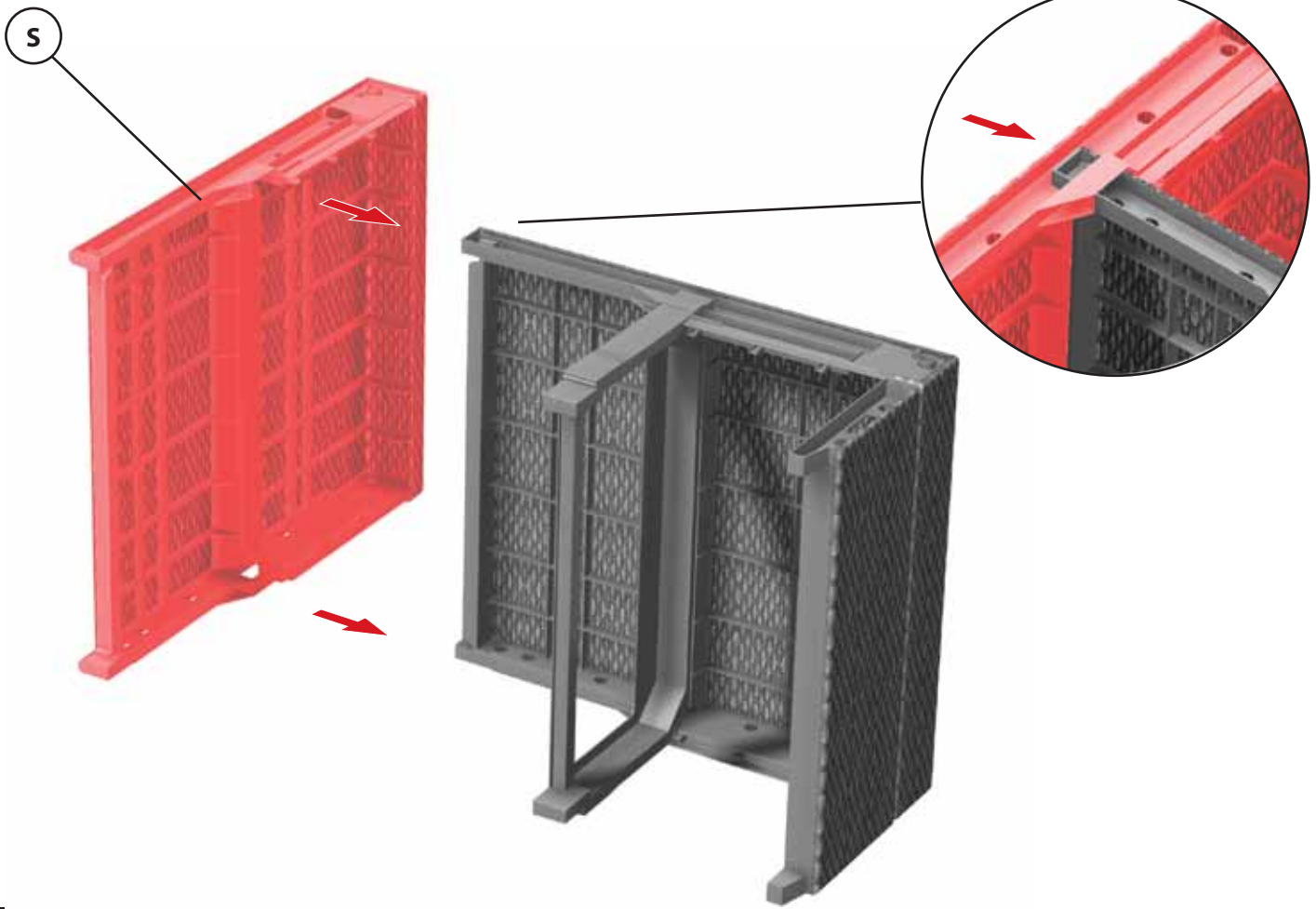

3

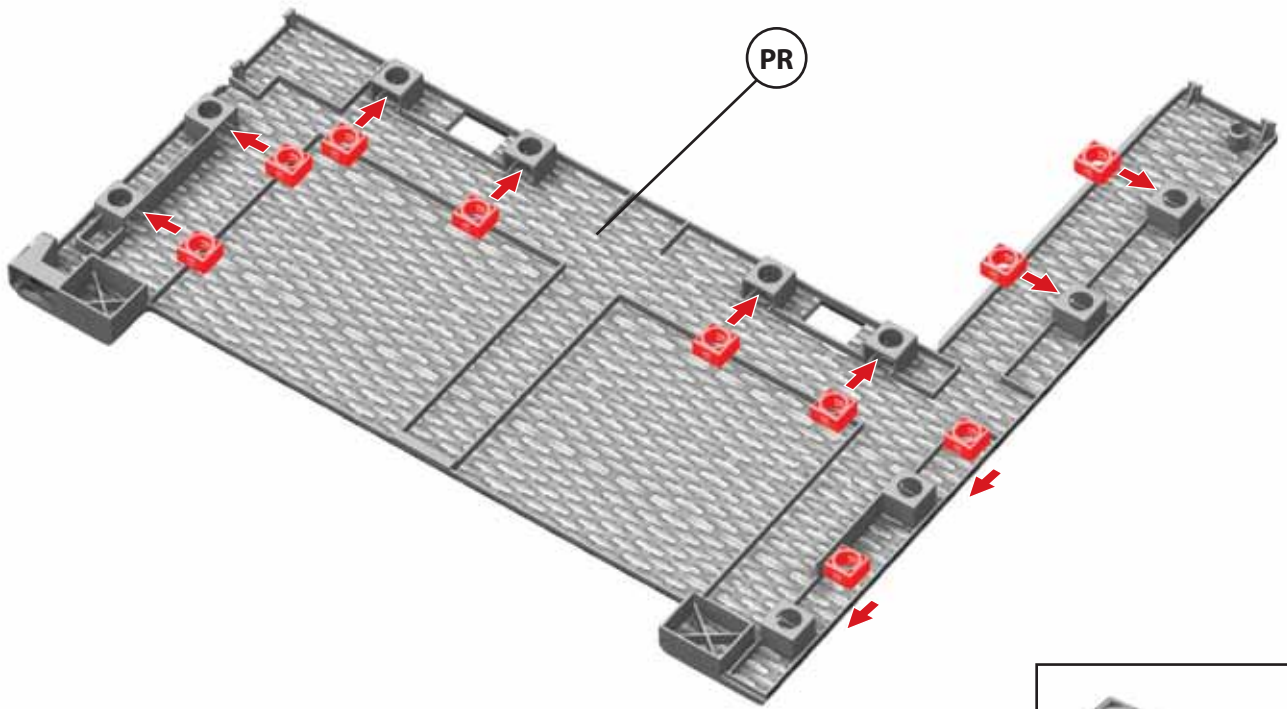

4

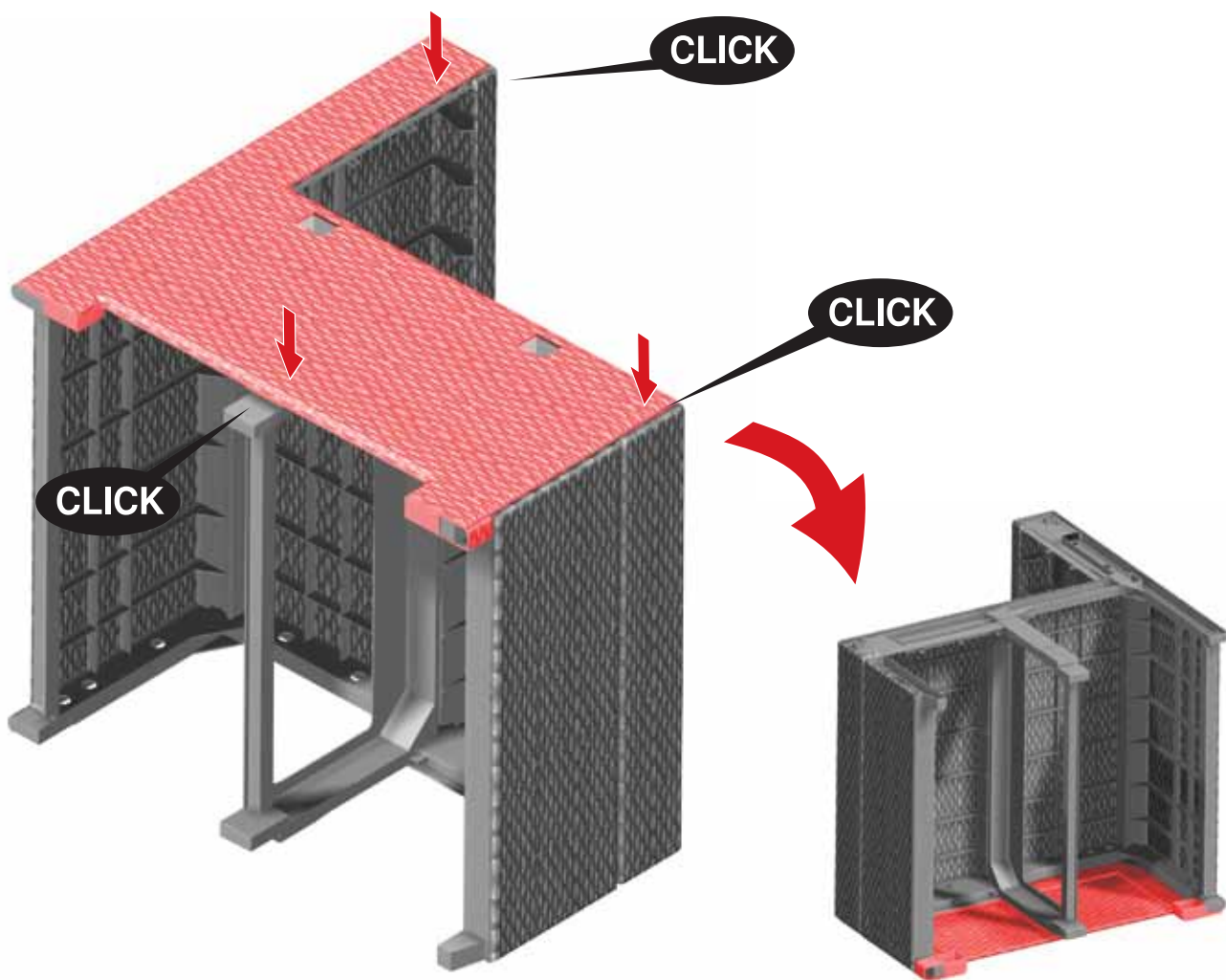
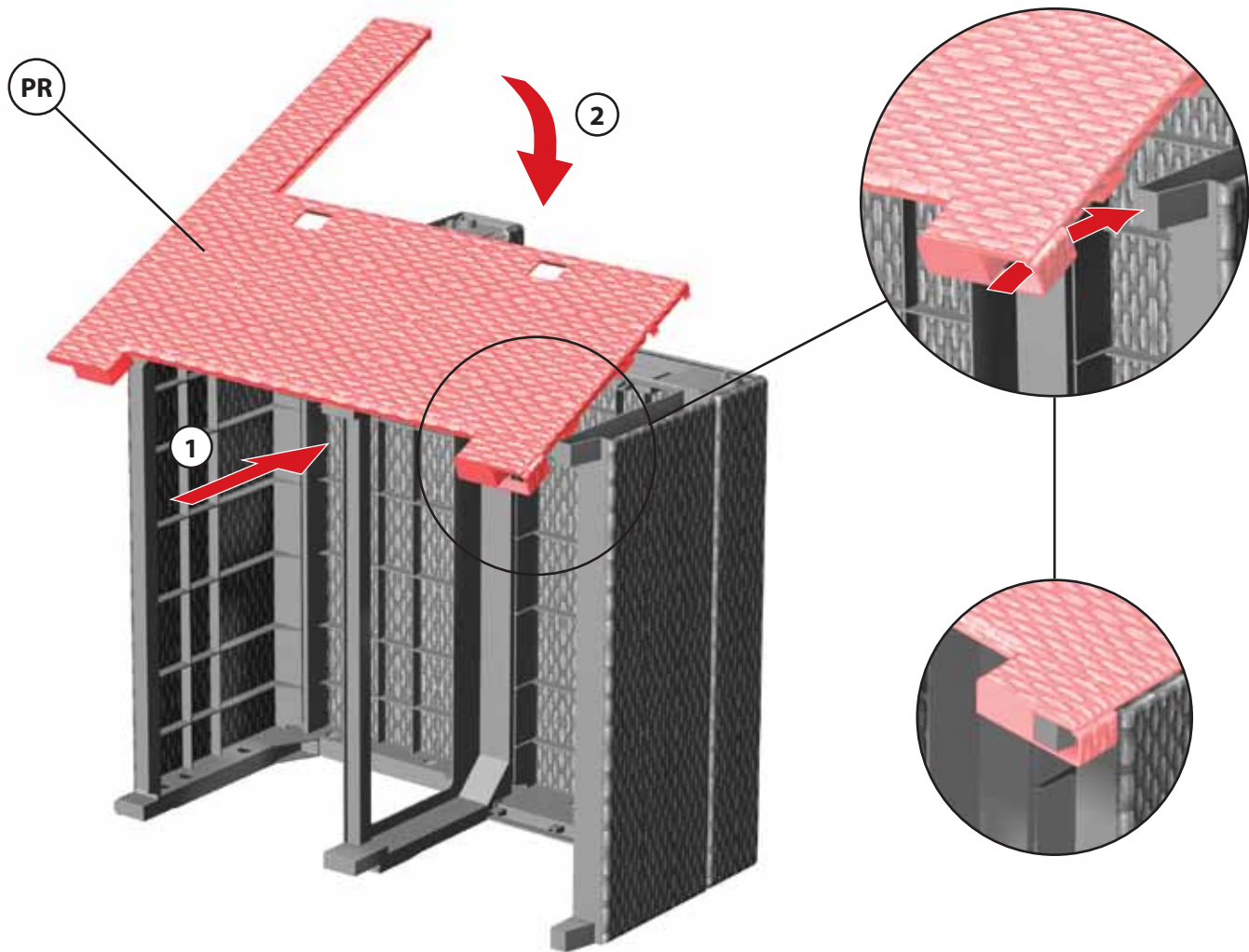

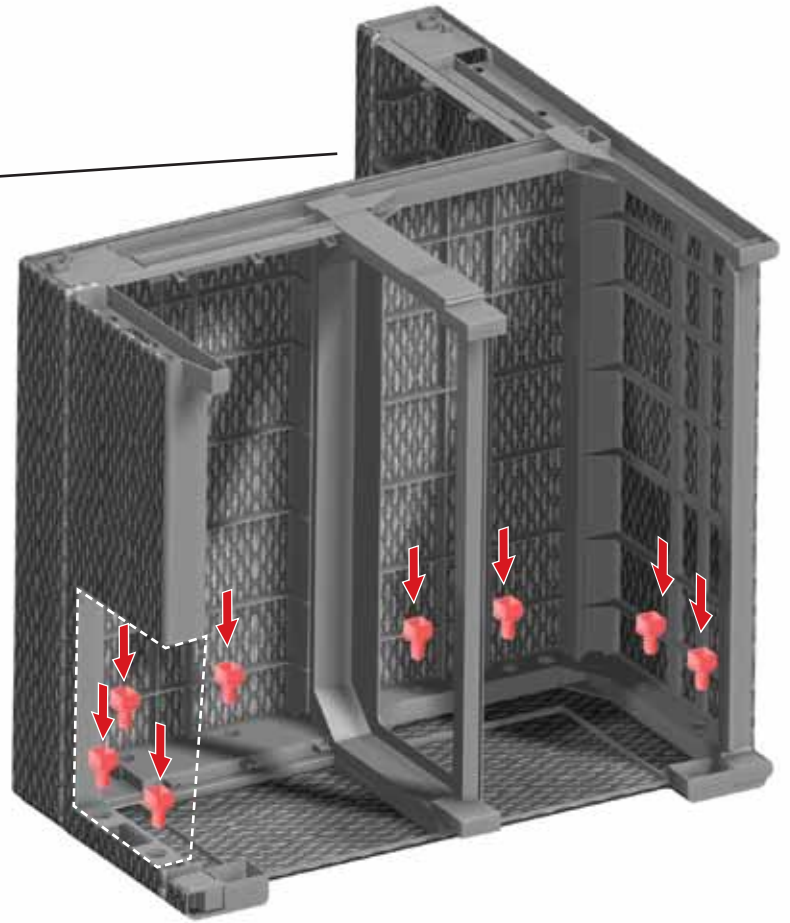
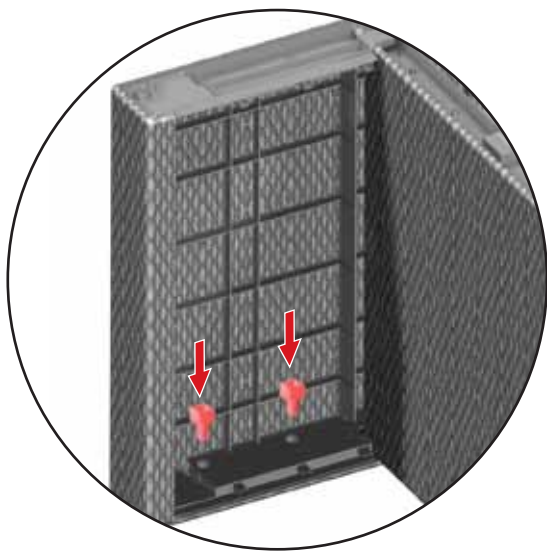

x 10

7

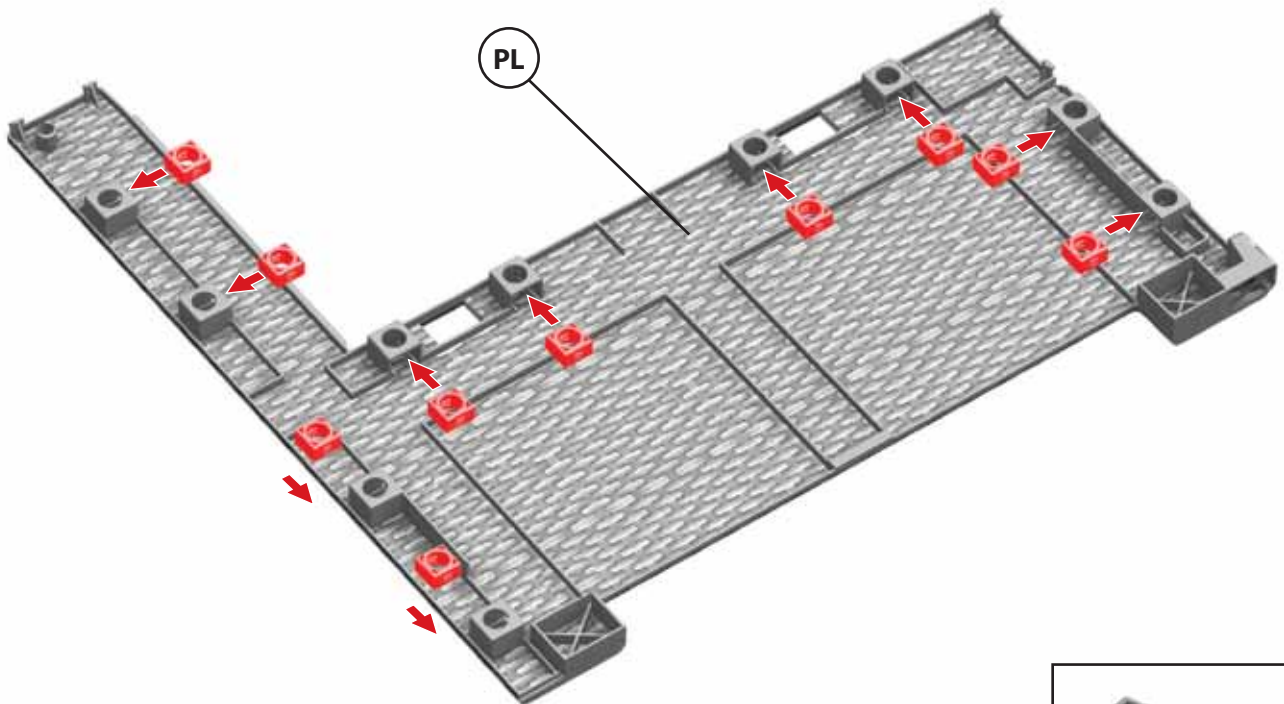

x 10

8

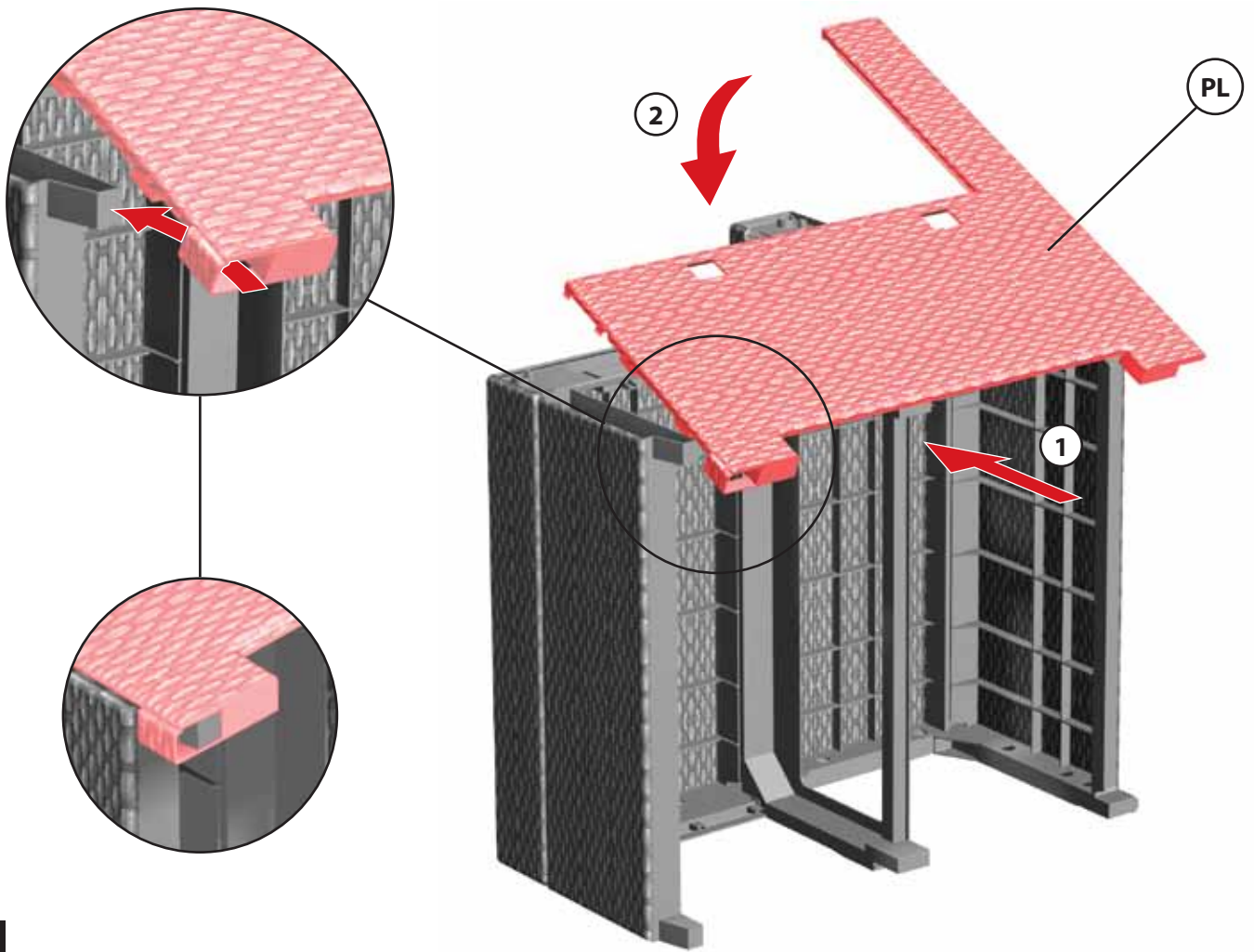

9

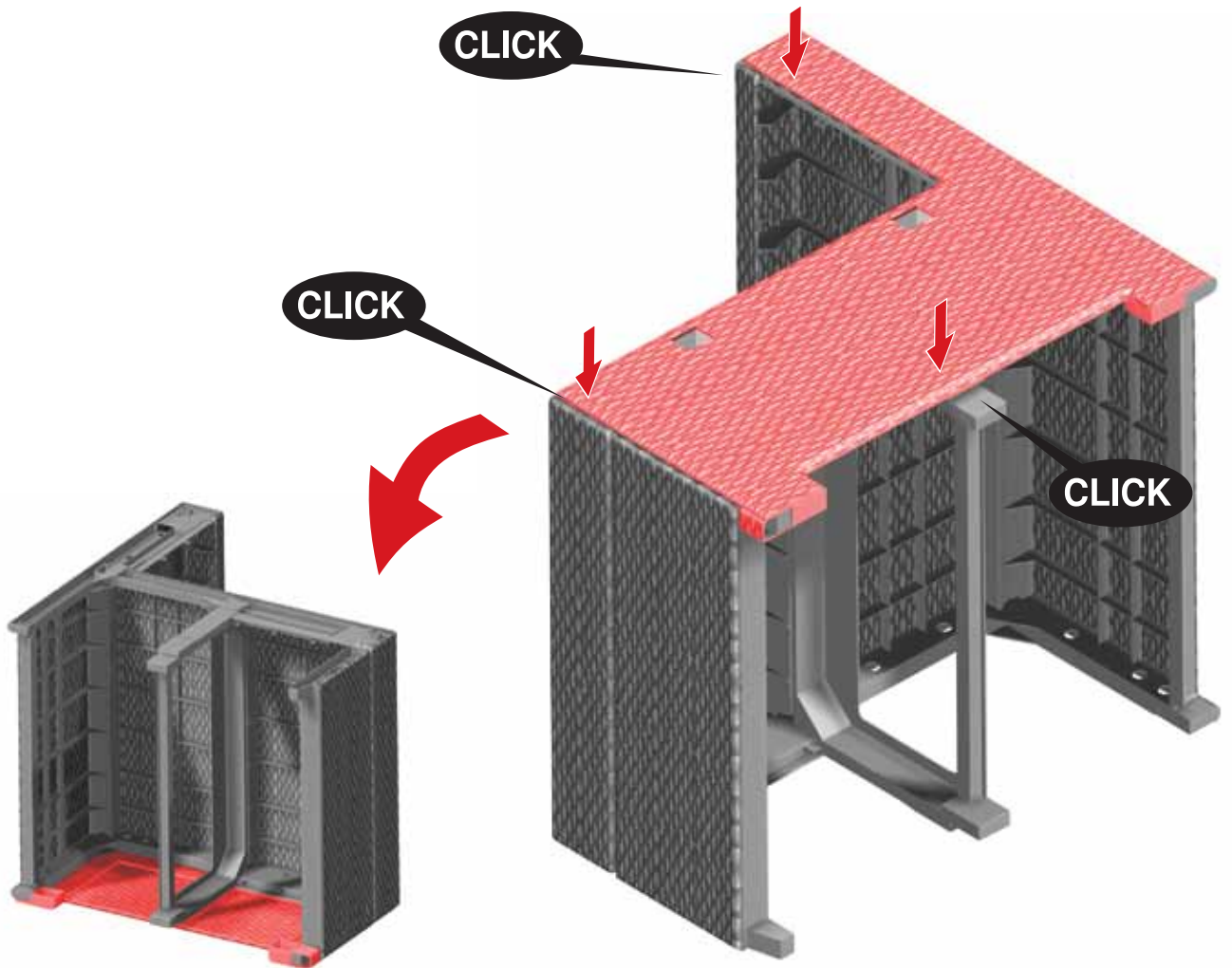

10

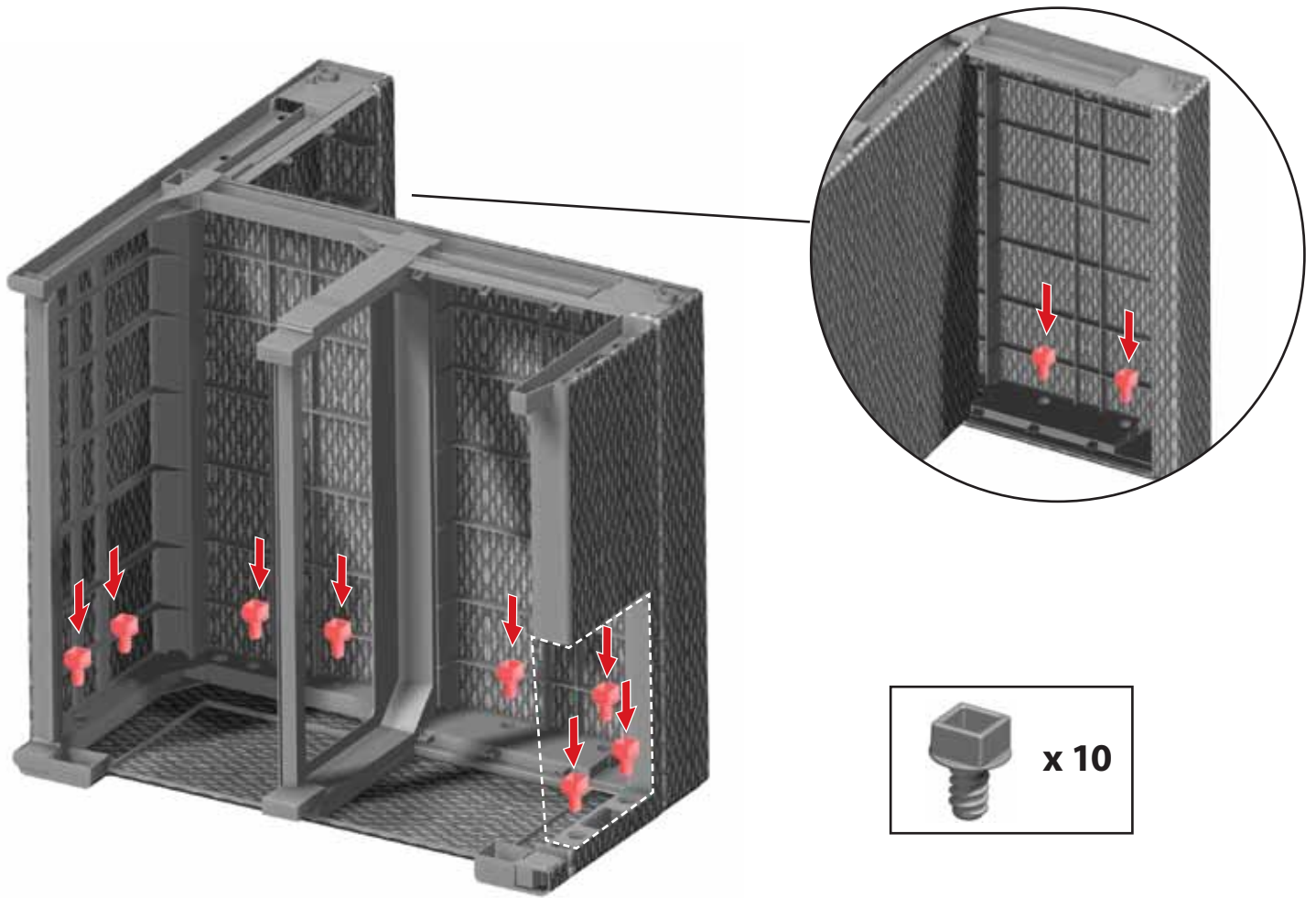

11

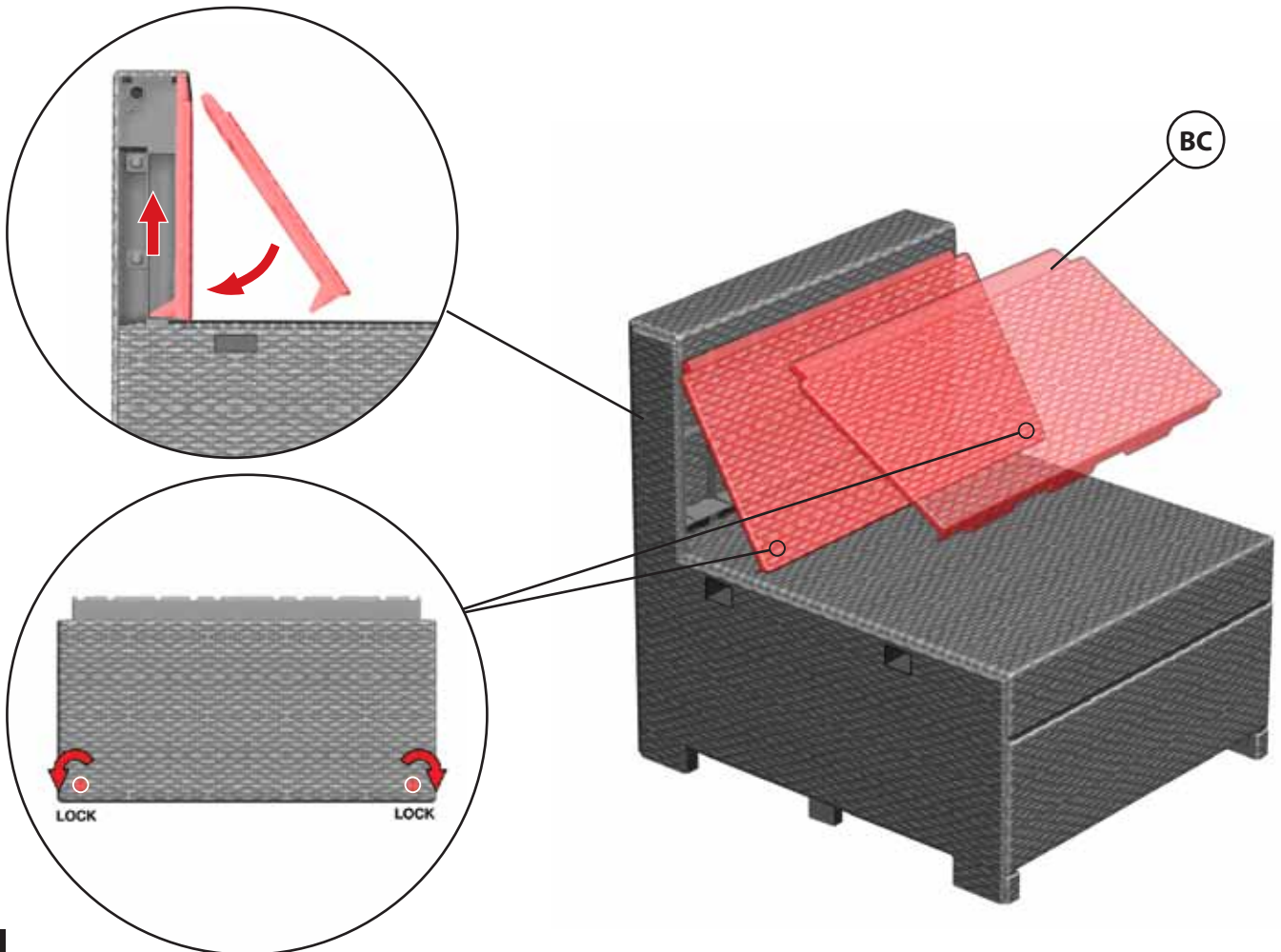

12

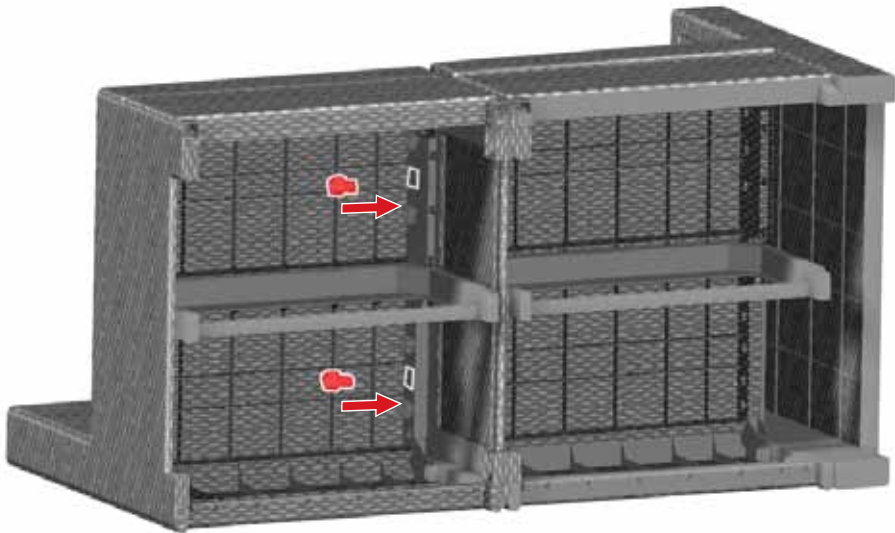
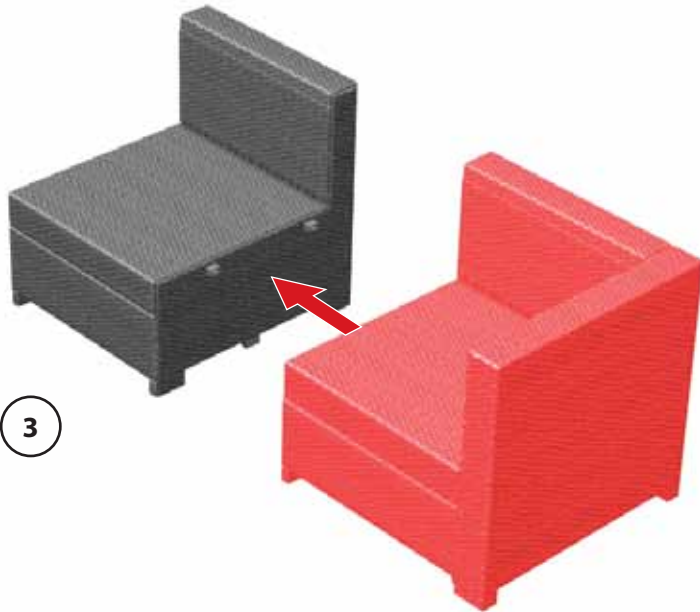
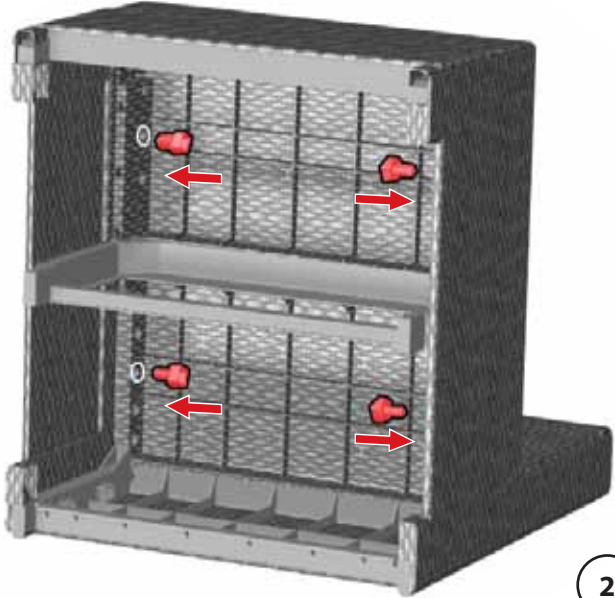
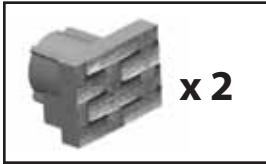
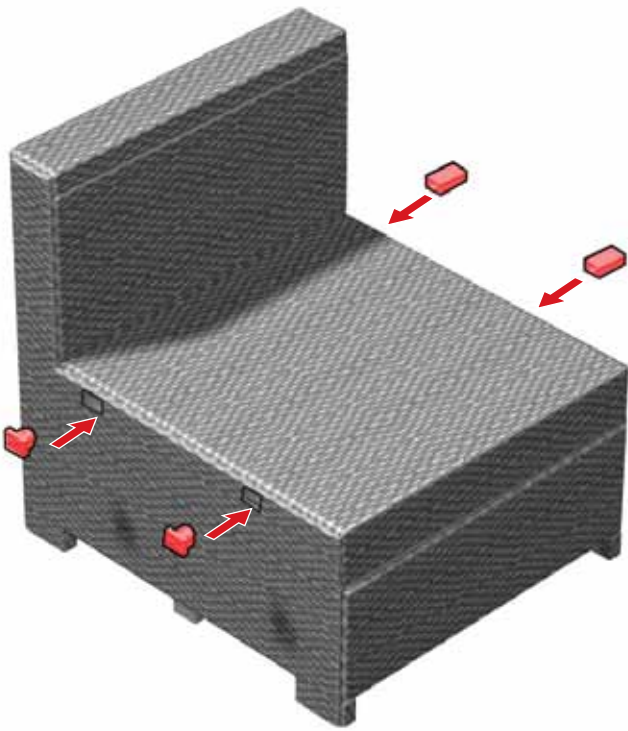

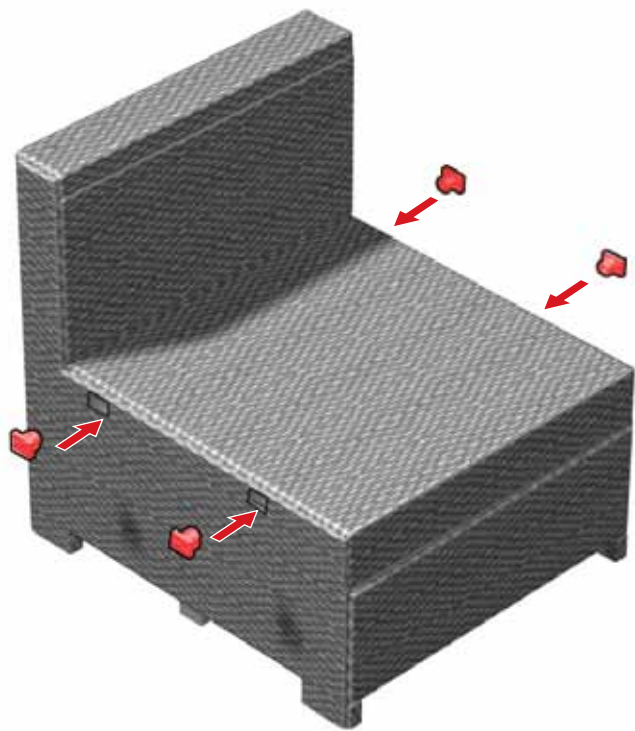

1

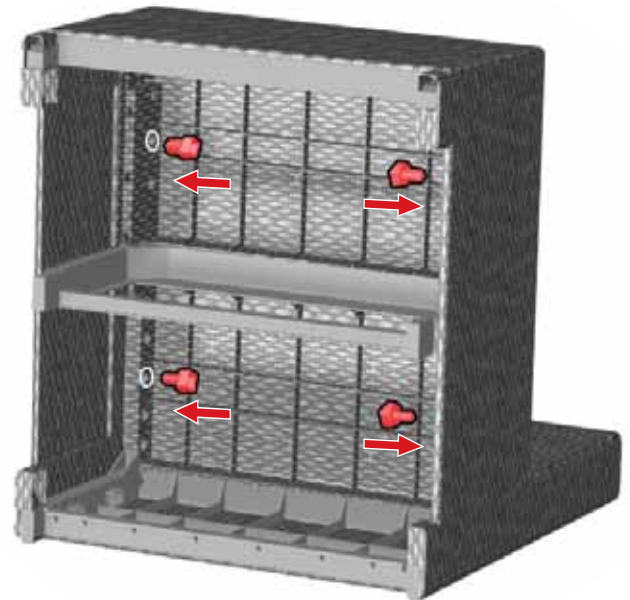
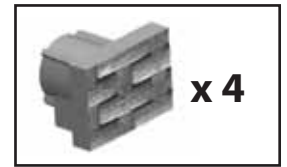

2

13B

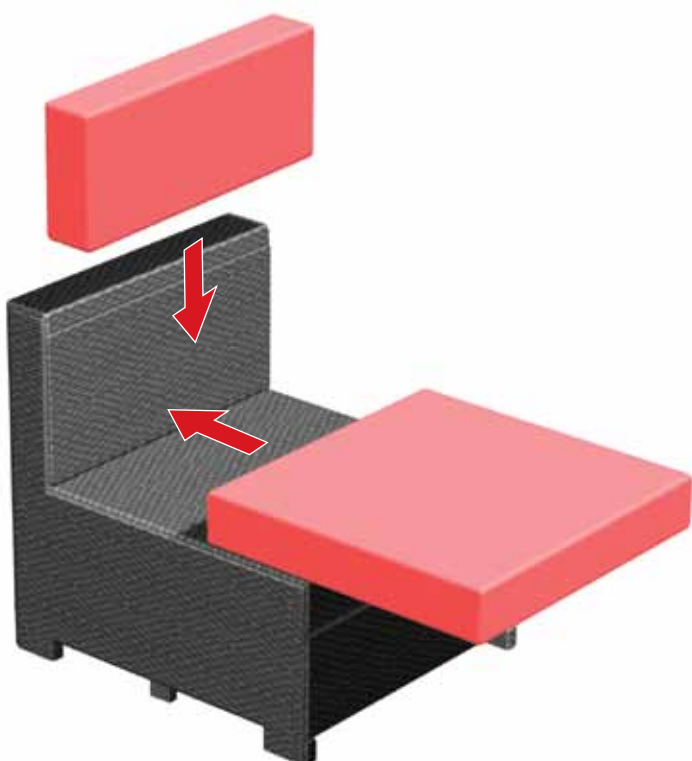

14

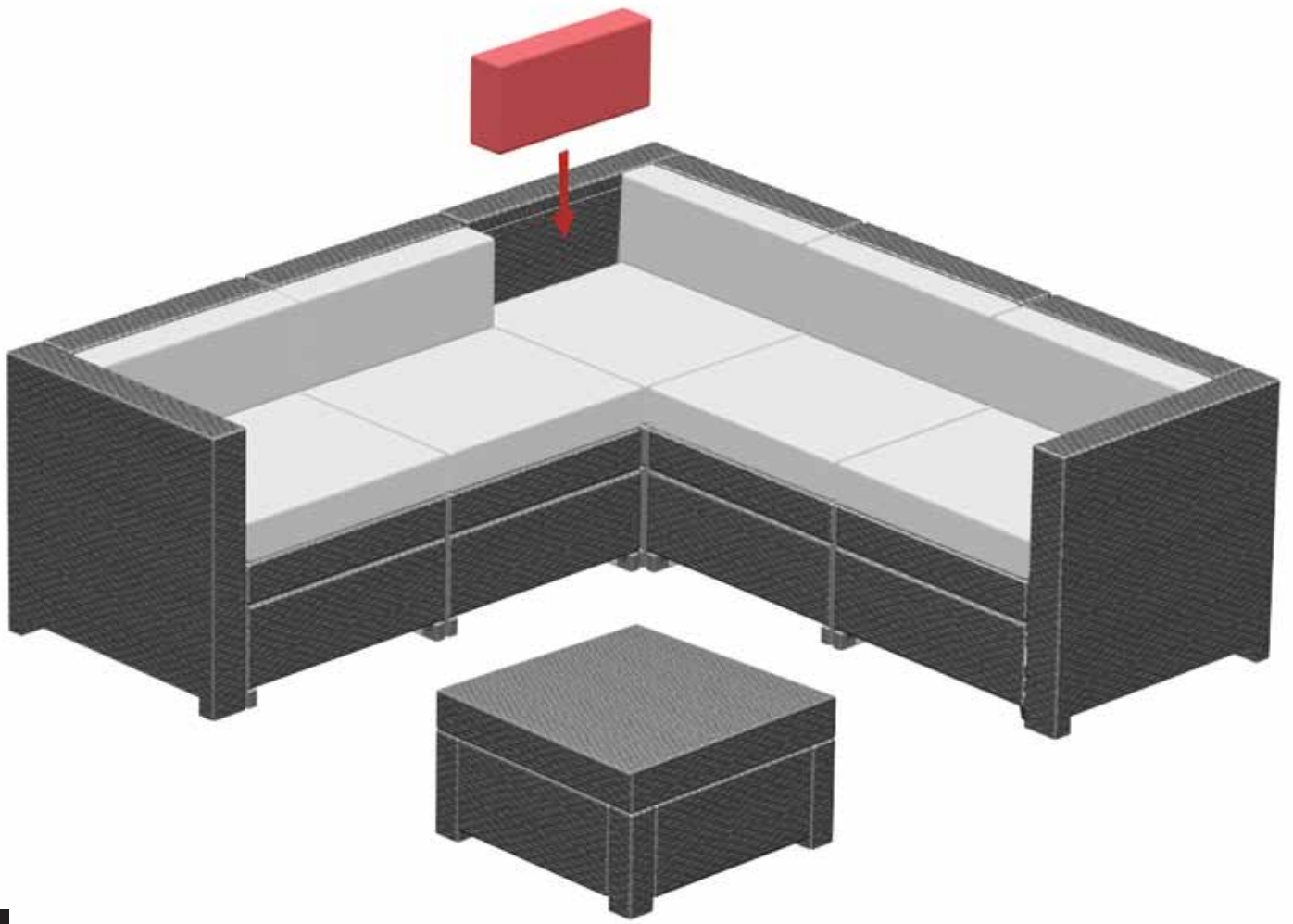

15

